

kWh

Dyneo® Motors & Drives

Powerdrive FX & MD2 variable speed drives
LSRPM - PLSRPM permanent magnet synchronous motors
18 kW to 500 kW



LEROY-SOMER™

Nidec
All for dreams



Powerdrive FX range
18 kW to 90 kW

Drives with dynamic braking

Integrating C-Light 4 Quadrant technology, the Powerdrive FX variable speed drive offers an exceptionally compact regenerative solution. Thanks to latest generation high-performance control, Powerdrive FX is ideally suited to sensorless control of permanent magnet motors.



Powerdrive MD2 range
45 kW to 2.8 MW

“Ready-to-use” variable speed drive for high-power Process applications

With many years of experience in contact with users and machine manufacturers, Nidec has responded to the sector's expectations and offers the Powerdrive MD2 range of drives:

- **Ready to use:** everything is fitted, wired up and tested
- **Compact and rugged:** ideal for integration either in an equipment room or in the machine environment
- **Protected:** enhanced protection against electrical disturbance
- **Simple:** easy to install and operate
- **Available:** high level of reliability, preventive diagnostics and modular construction



LSRPM - IP55

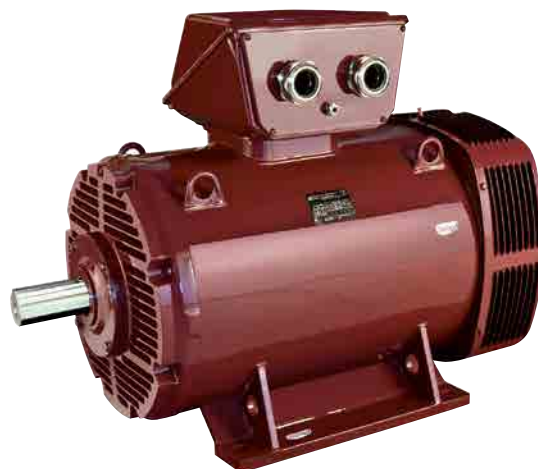

PLSRPM - IP23

Motor range Dyneo® 3 to 500 kW

Innovation you can place your trust in

Alliance of magnet rotor technology and the asynchronous motor's tried and tested mechanism

Exceptional savings

On the purchase price:

- Simplification through elimination of transmission devices (pulleys, belts, etc.), extended speed range
- Longer service life
- Reduction in the weight and dimensions of the driven machine: up to 3 frame sizes smaller

On energy bills:

- High efficiency over the entire speed range

On maintenance:

- Less stress on the mechanism

Performance

- Guaranteed torque over the entire speed range
- Optimized power with centrifugal torque operation

Energy savings

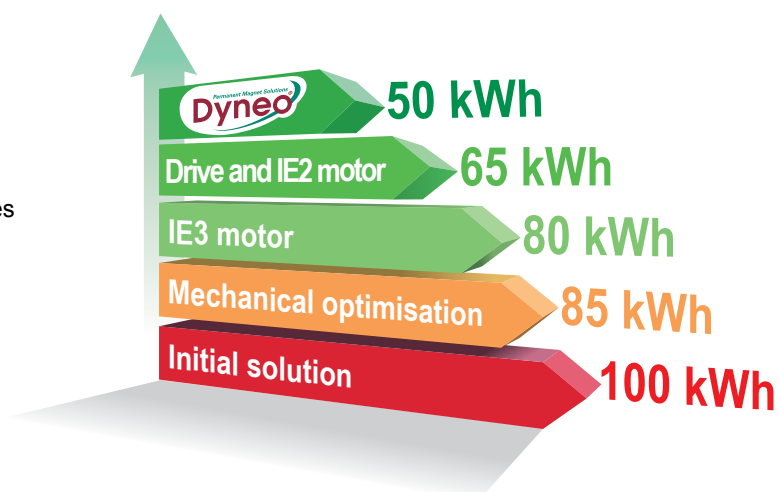

Interchangeability

LSRPM motors of the 1500 range are also available with an IEC mechanism equivalent to induction motors with the same power rating, to make it easier to update existing installations.

High-performance solutions

Whether you wish to ensure your installation complies with new efficiency directives or to benefit from a premium energy-efficient solution, Nidec offers the Dyneo® range, an optimized, high-performance, approved and compatible drive/permanent magnet motor package.

Powerdrive MD2 and FX drives combined with LSRPM or PLSRPM motors offer solutions adapted to the industrial environment, producing optimum electrical and mechanical performance, that are ideal for saving energy and substantially cutting operating costs:

- Extended speed range
- High torque
- Premium efficiency
- Unrivalled compactness
- Reduced maintenance
- Motor control with or without sensor feedback

The **Powerdrive MD2** range is suitable for high-power Process applications. It includes compact, rugged, ready-to-use IP21 or IP54 products, in which all the functions required by the application are fitted, wired up and tested. The range is available in a wall-mounting version up to 250 kW (MD2MS) or in a free-standing cubicle (MD2S).

The **Powerdrive FX** range is particularly suitable for 4-quadrant applications initially using a braking resistor, with high inertia, requiring cyclical decelerations and/or fast stops, or requiring a very compact solution: hoisting, escalators, the timber industry, ventilation, etc. Further information about the products described in this catalogue is available in the corresponding technical documentation.

Sensorless control

Fifteen years' experience of controlling permanent magnet motors and ongoing collaboration between our motors and drives development teams have allowed us to test different algorithms for total sensorless control of the majority of Process applications (pumps, compressors, fans, pressure boosters, centrifuges, separators).

The aim is to offer the user the benefit of the excellent performance of permanent magnet motors with the simplicity of induction motors.

Single manufacturer warranty

A motor-drive system produced by a single manufacturer ensures optimum performance obtained by using components designed to work together, with a global warranty from a single company.



Express Availability!

Delivery times EX WORKS: 5 or 10 working days for a selection of drive systems

Contents

INTRODUCTION

Powerdrive FX offer	6
Powerdrive MD2 offer	7
LSRPM - PLSRPM motors	8
Motors & Drives designation	9
Selection method	10-11
Efficiency	12

SELECTION

1500 range	13
1800 range	14
2400 range	15
3000 range	16
3600 range	17
4500 range	18
5500 range	19

PERFORMANCE

1500 range - 0 to 1500 rpm Torque from 0 to 2300 N.m	20-21
1800 range - 0 to 1800 rpm Torque from 0 to 2300 N.m	22-23
2400 range - 0 to 2400 rpm Torque from 0 to 1400 N.m	24-25
3000 range - 0 to 3000 rpm Torque from 0 to 1600 N.m	26-27
3600 range - 0 to 3600 rpm Torque from 0 to 1500 N.m	28-29
4500 range - 0 to 4500 rpm Torque from 0 to 360 N.m	30
5500 range - 0 to 5500 rpm Torque from 0 to 240 N.m	31

DRIVE DIMENSIONS

Powerdrive FX & MD2	32
---------------------------	----

MOTOR DIMENSIONS

Shaft extensions	33
Foot mounted IM B3	34
Foot and flange mounted IM B35	35
Flange mounted IM B5	36
Motors with options	37

INSTALLATION AND OPTIONS

General	38
Good wiring practice	39
Typical variable speed drive installation	40
Selection of position sensor	41
Encoders	42
Reinforced insulation	43
Forced ventilation - Cable glands	44
Thermal protection	45

MOTOR CONSTRUCTION

Definition of "Index of Protection" (IP/IK)	46
External finish	47
Mounting arrangements	48
Bearings and lubrication	49
Terminal box and connection	50-52
Motor vibration levels	53
Quality commitment	54
Standards and approvals	55-56
Nameplates	57

GENERAL INFORMATION

Configurator	58
--------------------	----

Nidec reserves the right to modify the design, technical specifications and dimensions of the products and solutions shown in this document. The descriptions cannot in any way be considered contractual.

Dyneo® Motors & Drives

Powerdrive FX & MD2 variable speed drives/LSRPM-PLSRPM permanent magnet synchronous motors

Introduction

22 to 90 kW: the Powerdrive FX offer

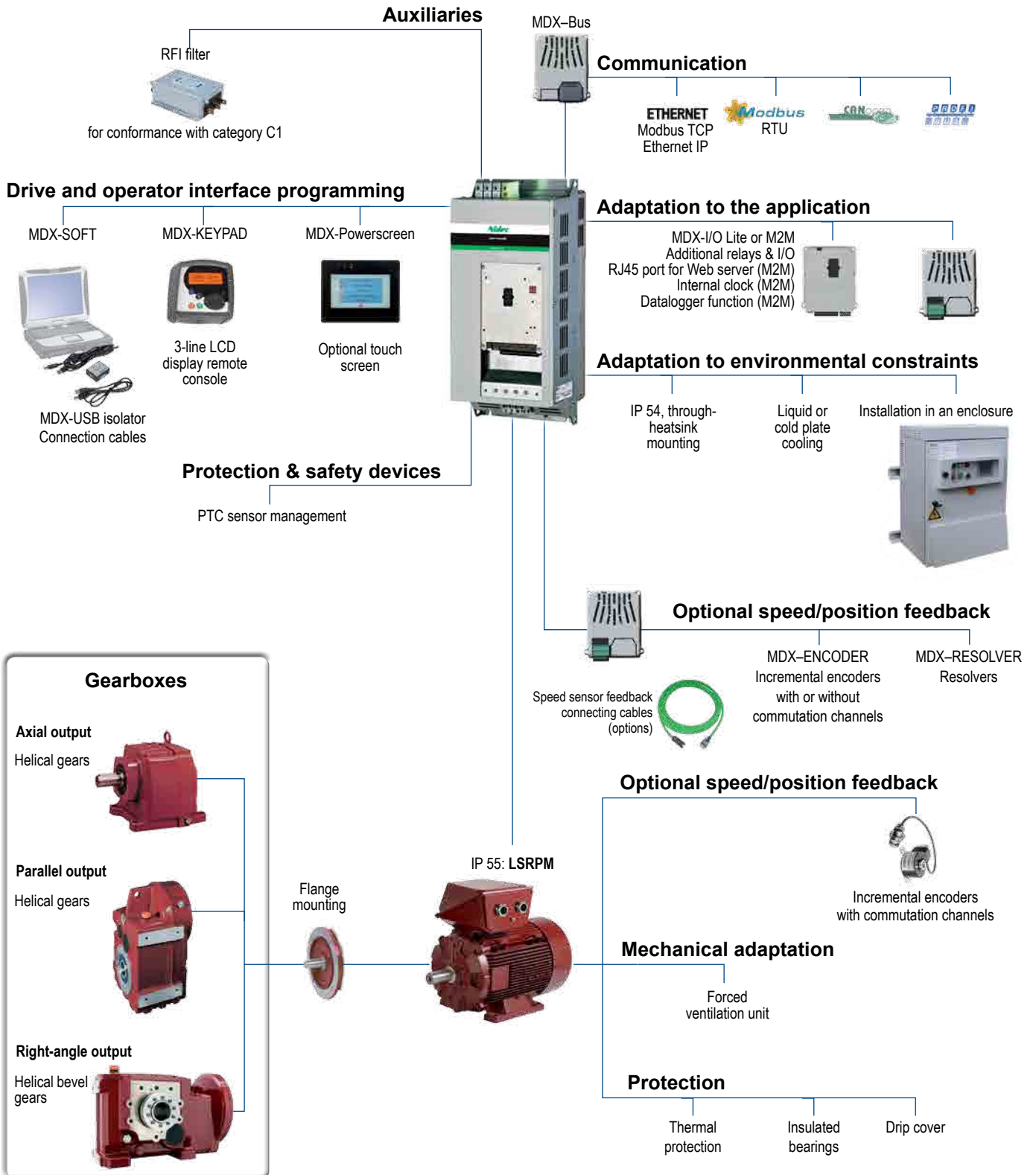

The detailed characteristics of the products and options are described in the technical documents for the relevant products (refer to manual ref. 4155 for LSRPM-PLSRPM motors and manual refs. 4972 and 4617 for the Powerdrive FX drive).

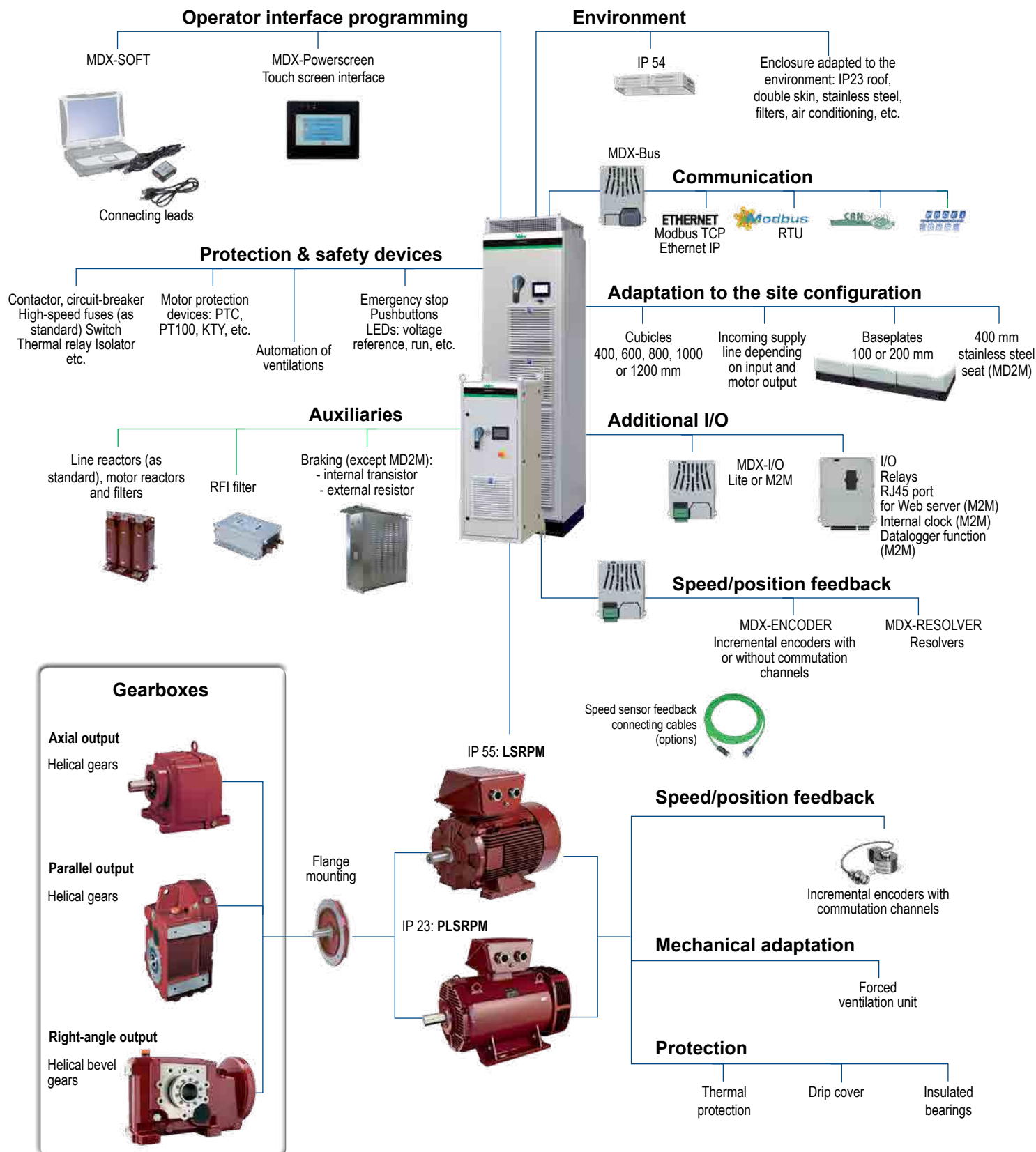

The detailed characteristics of the products and options are described in the technical documents for the relevant products (refer to manual ref. 4155 for LSRPM-PLSRPM motors and manual refs. 4972, 5114 and 4617 for the Powerdrive MD2 drive).

Introduction

LSRPM - PLSRPM motors

Description of motors

Description	Materials	Comments
Frame	LSRPM: Aluminium alloy PLSRPM: Steel	<ul style="list-style-type: none"> - With integral or screw-on feet, or without feet - 4 or 6 fixing holes for housings with feet - Lifting rings - Earth terminal with an optional jumper screw
Stator	Insulated low-carbon magnetic steel laminations Electroplated copper	<ul style="list-style-type: none"> - Low carbon content guarantees long-term lamination pack stability - Welded laminations - Optimised magnetic circuit - Insulation or coating system making it possible to withstand the sudden voltage variations caused by the high switching frequencies of IGBT transistor drives - Class F insulation - Thermal protection provided by PTC sensors (1 per phase, 2-wire output)
Rotor	Insulated low-carbon magnetic steel laminations Aluminium alloy Nd-Fe-B magnet	<ul style="list-style-type: none"> - Magnet fixing system, patented by Leroy-Somer - Rotor balanced dynamically with a half-key (H)
Shaft	Steel	
End shields	Cast iron	
Bearings and lubrication		<ul style="list-style-type: none"> - Ball bearings, C3 play - Preloaded NDE bearings - Greased for life up to frame size 200 - Open type, regreasable from frame size 250 upwards - Insulated bearings depending on the speed range
Labyrinth seal Lipseals	Plastic or steel Synthetic rubber	<ul style="list-style-type: none"> - Lipseal or deflector at drive end for all flange mounted motors - Lipseal, deflector or labyrinth seal for foot mounted motors
Fan	Composite material or aluminium alloy or steel	- Bi-directional
Fan cover	Pressed steel	- Fitted, on request, with a drip cover for operation in vertical position, shaft end facing down
Terminal box	Aluminium alloy	<ul style="list-style-type: none"> - Fitted with a terminal block with 3 or 6 steel terminals as standard (brass as an option) - Pre-drilled terminal box without cable glands or with undrilled mounting plate (optional cable gland) - 1 earth terminal in each terminal box - Connection on stepped strips for PSLRPM 315LD1 motors



The motor rotor contains a powerful magnetic field. When the rotor is separated from the motor, its field can affect pacemakers or disturb digital devices such as watches, mobile phones, etc.

Assembly or maintenance of the rotor must not be carried out by people with a pacemaker or any other implanted medical electronic device.

The assembled motor presents no risk.

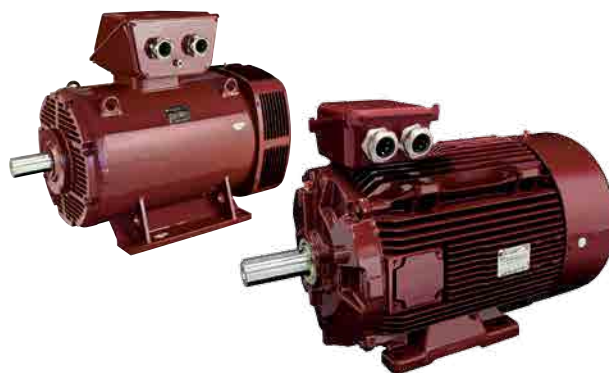

Introduction

Motors & Drives designation

Drive

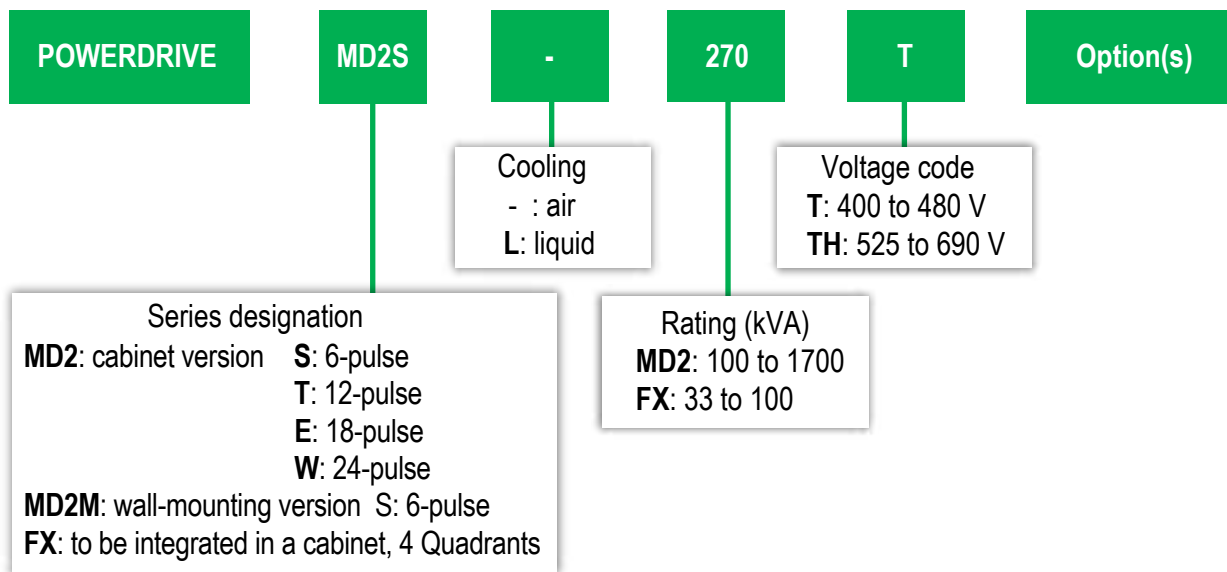

Motor

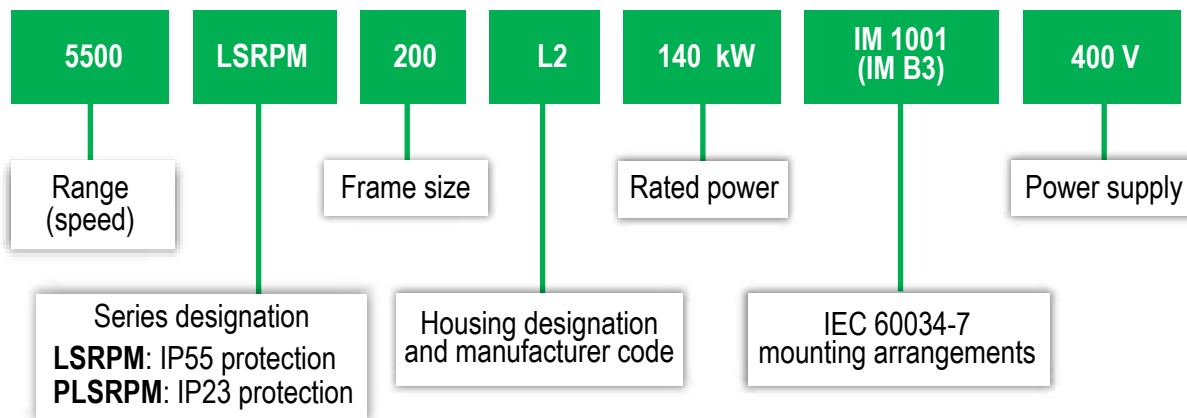

Introduction

Selection method

The LSRPM or PLSRPM motor associated with Powerdrive MD2 or FX has different characteristics according to the selected control mode. This should be determined according to:

- the starting torque
- the machine's rated speed (or regulation)

The diagram below can be used to determine the most suitable control mode for the application.

Sensorless mode is particularly suitable for applications that do not require high starting torque.

With sensor feedback (closed loop), Powerdrive MD2 or FX drives offer high performance for the most demanding applications.

To select the position sensor, see the "Selection of position sensor" section in the "Installation and options" chapter.

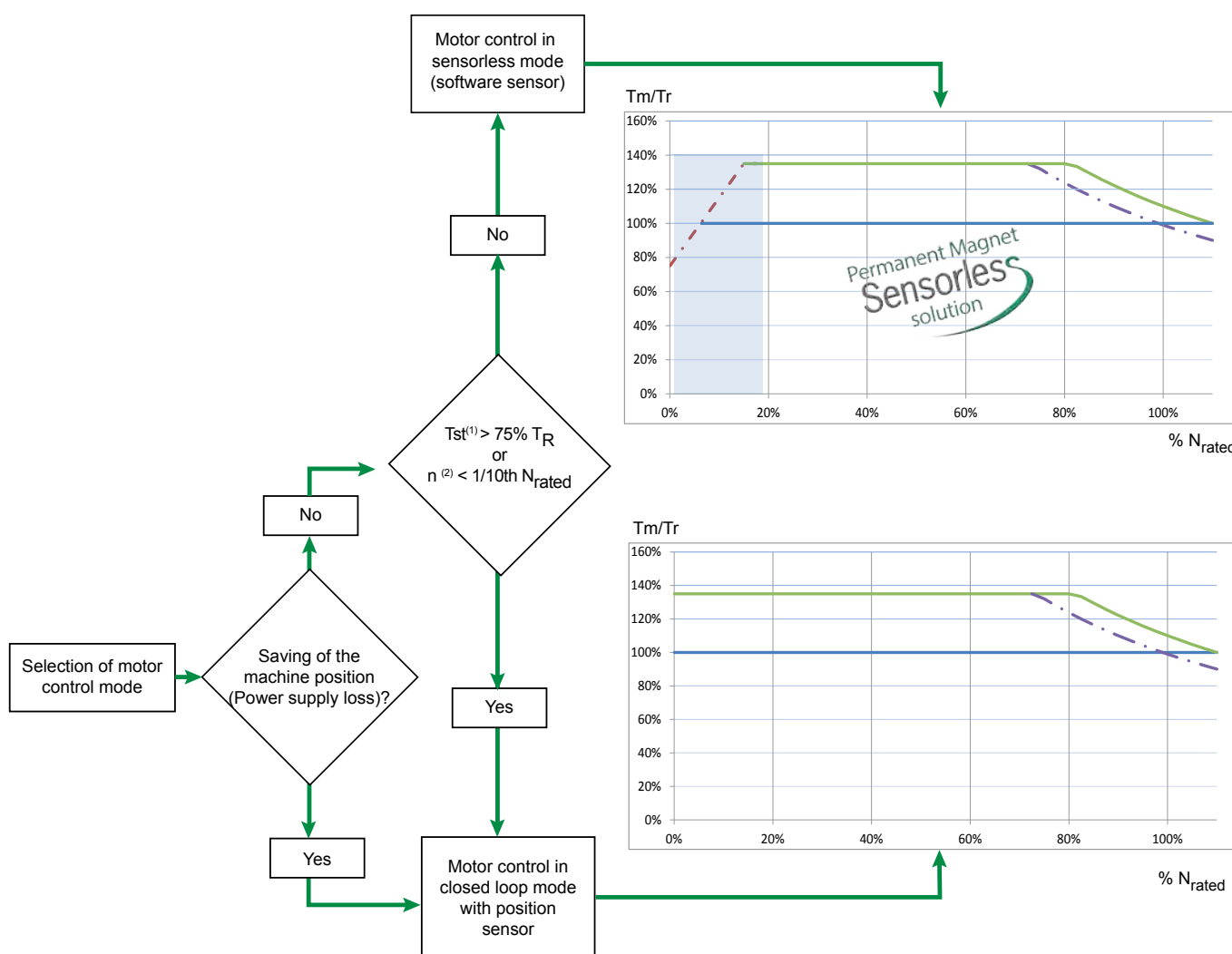

(1) Between 0 and 10% of rated speed

(2) Minimum speed

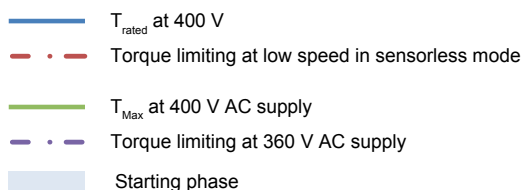

Introduction

Selection method

Example:

A centrifugal pump requires torque of 300 N.m at 1500 rpm in continuous duty (regulation from 600 to 1500 rpm). The maximum torque is < 110% of Tn and the starting torque is negligible.

Step 1: select the control mode

Depending on the criteria, Sensorless control may be suitable.

Step 2: select the Motors & Drives

In the table for the 1500 range, select the drive rating according to the rated and maximum torque required by the application.

Motor				Motors & Drives											Motor	
Motor type	Motor with IEC mech.	Rated power	Efficiency IEC 60034-2-1	Type of Powerdrive MD2/FX	Available power	Rated torque	Sensorless starting torque	Maximum torque	Max. torque/Rated torque	Max. torque at rated speed	Rated current	Max. current /Rated current	Minimum switching frequency	Motor-drive efficiency	Moment of inertia	Weight
		Pn (kW)	η 4/4		Pn (kW)	Tr (N.m)	75% Tr (N.m)	Tmax (N.m) ⁽¹⁾	Tmax/Tr	(N.m) ⁽²⁾	Ir (A) ⁽³⁾	Imax/Ir	Fs (kHz) ⁽⁴⁾	η 4/4	J (kg.m ²)	IM B3 (kg)
LSRPM 200 LU		55	95.5	FX 60T	55	350	263	381	1.09	358	110	1.08	4	93.6	0.26	190
				MD2 60T	55	350	263	403	1.15	370	110	1.18	3	93.6	0.26	190
				FX 75T	55	350	263	464	1.3	402	110	1.40	4	93.6	0.26	190
				MD2 75T	55	350	263	480	1.37	411	110	1.45	3	93.6	0.26	190

Selected equipment:

1500 LSRPM 200 LU 55 kW motor and Powerdrive MD2 60T drive.

Note: If a short lead time is necessary, opt for Express Availability products, i.e. a 1500 LSRPM 250 MY 55 kW motor and a Powerdrive MD2M 60T drive.

Step 3: check the selection

Using the motor thermal curve, check that the motor is suitable for the torque range required by the application.

1500 range Torque from 145 to 350 N.m

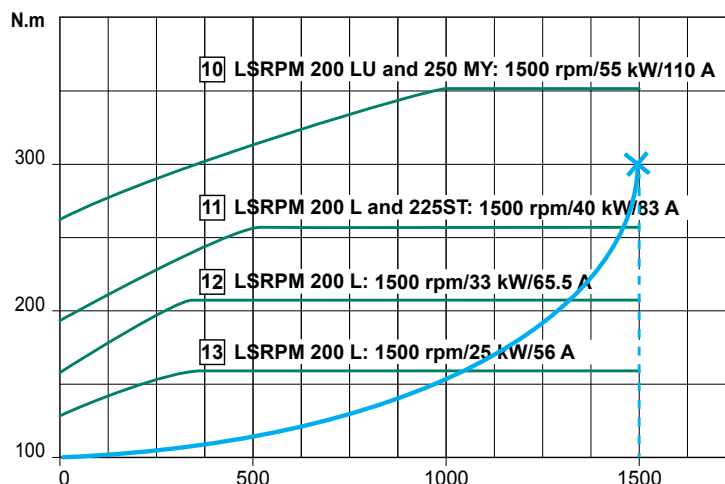

The efficiency of Leroy-Somer permanent magnet synchronous motors is higher than those of asynchronous motors and more stable over the entire selected speed range (see graph below).

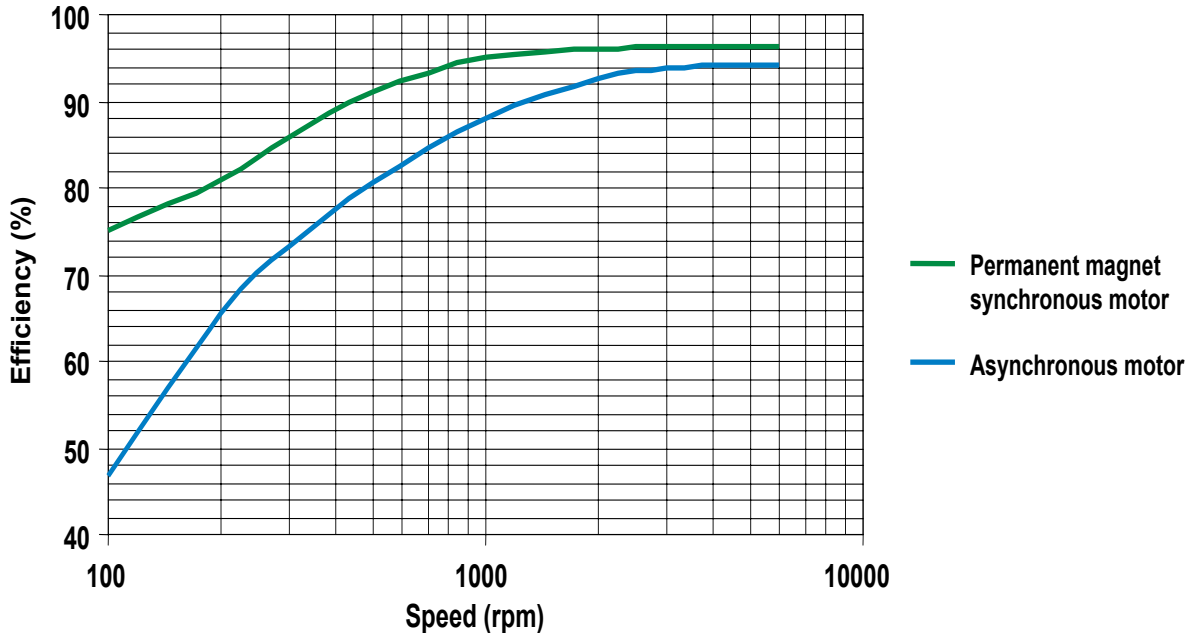

Efficiency of permanent magnet induction motors

Apart from a few exceptions, synchronous motors cannot operate correctly on a traditional sinusoidal AC supply. They are practically always supplied via a drive. This catalog gives the efficiencies of motors & drives, controlled by a Nidec drive.

Efficiency of asynchronous motors supplied via drives

As a general rule, the efficiencies of asynchronous motors given in the catalogues are values measured on a sinusoidal AC supply at the rated speed.

The voltage and current waveforms created by the drive are not sinusoidal. Supplying power via a drive therefore results in additional losses in the motor. According to specifications 60034-17, these are estimated at 20% of the total losses. These losses have a direct impact on the “displayed” efficiency of the motor.

In variable speed mode, this efficiency should therefore be corrected in accordance with the formula: $\eta_2 = \eta_1 / (1.2 - 0.2 \eta_1)$

η_2 = efficiency of asynchronous motor obtained on a drive

η_1 = efficiency of asynchronous motor supplied from the AC supply

Example of induction/synchronous efficiency: 200 kW application at 3000 rpm

η_1 : Efficiency of the 200 kW, 2-pole asynchronous motor on 50 Hz AC supply = 96%

η_2 : Estimated efficiency of the same asynchronous motor supplied via a drive at 50 Hz

$\eta_2 = 0.96 / (1.2 - 0.2 \times 0.96) = 0.9524$ i.e. 95.24%

Efficiency of the equivalent synchronous motor = 97.3%

Class F - DT80K - S1 Self-Cooled - Altitude 1000 m max - Ambient temperature 40°C max

Power supply upstream from the 400 V drive

260 Drive limit

285 Motor limit

Motor				Motors & Drives											Motor	
Type of	Std IEC mech. (5)	Rated power Pr (kW)	Efficiency IEC 60034-2-1 η 4/4	Type of Powerdrive MD2/FX	Available power Pn (kW)	Rated torque Tr (N.m)	Sensorless starting torque 75% Tr (N.m)	Maximum torque Tmax (N.m) (1)	Max. torque / Rated torque Tmax/Tr	Maximum torque at rated speed (N.m) (2)	Rated current Ir (A) (3)	Max. current / Rated current Imax/Ir	Minimum switching frequency Fs (kHz) (4)	Motor-drive efficiency η 4/4	Moment of inertia J (kg.m²)	Weight IM B3 (kg)
LSRPM 160 MP	-	19.2	93.0	FX 33T	19.2	122	91.6	167	1.37	143	37	1.45	4.0	91.1	0.0514	69
LSRPM 160 LR	-	22.8	93.5	FX 33T	22.8	145	109	199	1.37	170	43	1.45	4.0	91.6	0.0626	79
LSRPM 200 L	-	25	94.0	FX 33T	25	159	119	179	1.12	166	56	1.14	4.0	92.1	0.13	135
				FX 40T	25	159	119	212	1.33	184	56	1.41	4.0	92.1	0.13	135
LSRPM 200 L	oui	33	94.6	FX 40T	33	210	158	246	1.17	224	65.5	1.21	4.0	92.7	0.17	150
				FX 50T	33	210	158	288	1.37	247	65.5	1.45	4.0	92.7	0.17	150
				FX 50T	40	255	191	287	1.13	266	82.9	1.15	4.0	93.3	0.2	165
LSRPM 200 L	-	40	95.2	FX 60T	40	255	191	345	1.36	297	82.9	1.44	4.0	93.3	0.2	165
				MD2 60T	40	255	191	350	1.37	299	82.9	1.45	3.0	93.3	0.2	165
				FX 50T	40	255	191	287	1.13	266	82.9	1.15	4.0	93.3	0.205	170
				MD2 60T	40	255	191	350	1.37	299	82.9	1.45	3.0	93.3	0.205	170
LSRPM 200 LU	-	55	95.5	FX 60T	55	350	263	381	1.09	358	110	1.08	4.0	93.6	0.26	190
				MD2 60T	55	350	263	403	1.15	370	110	1.18	3.0	93.6	0.26	190
				FX 75T	55	350	263	464	1.33	402	110	1.40	4.0	93.6	0.26	190
				MD2 75T	55	350	263	480	1.37	411	110	1.45	3.0	93.6	0.26	190
				FX 60T	55	350	263	381	1.09	358	110	1.08	4.0	93.6	0.26	196
LSRPM 250 MY	oui	55	95.5	MD2 60T	55	350	263	403	1.15	370	110	1.18	3.0	93.6	0.26	196
				FX 75T	55	350	263	464	1.33	402	110	1.40	4.0	93.6	0.26	196
				MD2 75T	55	350	263	480	1.37	411	110	1.45	3.0	93.6	0.26	196
				FX 75T	70	446	334	492	1.10	460	142	1.11	4.0	93.8	0.32	223
LSRPM 225 MR1	-	70	95.7	MD2 75T	70	446	334	507	1.14	468	142	1.16	3.0	93.8	0.32	223
				MD2 100T	70	446	334	593	1.33	514	142	1.41	3.0	93.8	0.32	223
				FX 100T	70	446	334	602	1.35	519	142	1.43	4.0	93.8	0.32	223
				FX 100T	85	541	406	589	1.09	554	174.9	1.08	4.0	93.7	0.65	285
LSRPM 250 ME	-	85	95.6	MD2 100T	85	541	406	610	1.13	565	174.9	1.14	3.0	93.7	0.65	285
				MD2 120T	85	541	406	703	1.30	615	174.9	1.37	3.0	93.7	0.65	285
				MD2 150T	85	541	406	742	1.37	636	174.9	1.45	3.0	93.7	0.65	285
				FX 100T	85	541	406	589	1.09	554	174.9	1.08	4.0	93.7	0.72	290
LSRPM 280 SCM	oui	85	95.6	MD2 100T	85	541	406	610	1.13	565	174.9	1.14	3.0	93.7	0.72	290
				MD2 120T	85	541	406	703	1.30	615	174.9	1.37	3.0	93.7	0.72	290
				MD2 150T	85	541	406	742	1.37	636	174.9	1.45	3.0	93.7	0.72	290
				MD2 120T	104	660	501	738	1.12	686	212 (214.9)	1.13	3.0	94.4	0.84	330
LSRPM 280 SC	-	105	96.3	MD2 150T	105	669	501	917	1.37	785	214.9	1.45	3.0	94.4	0.84	330
				MD2 150T	125	796	597	969	1.22	870	245	1.27	3.0	94.5	1	380
LSRPM 280 SD	-	125	96.4	MD2 180T	125	796	597	1090	1.37	934	245	1.45	3.0	94.5	1	380
				MD2 150T	125	796	597	969	1.22	870	245	1.27	3.0	94.5	1.1	385
LSRPM 315 SN	oui	125	96.4	MD2 180T	125	796	597	1090	1.37	934	245	1.45	3.0	94.5	1.1	385
				MD2 150T	137	871	692	1040	1.19	943	250 (265)	1.25	3.0	94.4	1.8	568
LSRPM 280 MK1	-	145	96.3	MD2 180T	145	923	692	1200	1.30	1050	265	1.38	3.0	94.4	1.8	568
				MD2 150T	137	871	692	1040	1.19	943	250 (265)	1.25	3.0	94.4	1.9	575
LSRPM 315 MP1	oui	145	96.3	MD2 180T	145	923	692	1200	1.30	1050	265	1.38	3.0	94.4	1.9	575
				MD2 220T	175	1110	836	1330	1.19	1200	350	1.24	3.0	94.6	2.24	635
LSRPM 315 SP1	oui	175	96.5	MD2 270T	175	1110	836	1530	1.37	1310	350	1.45	3.0	94.6	2.24	635
				MD2 220T	212	1350	1050	1480	1.10	1380	400 (415)	1.09	3.0	94.8	2.7	715
				MD2 270T	220	1400	1050	1710	1.22	1530	415	1.28	3.0	94.8	2.7	715
LSRPM 315 MR1	oui	220	96.7	MD2 340T	220	1400	1050	1920	1.37	1640	415	1.45	3.0	94.8	2.7	715
				MD2 270T	240	1530	1190	1700	1.11	1590	470 (490)	1.13	3.0	95.0	2.9	715
				MD2 340T	250	1590	1190	2030	1.28	1790	490	1.35	3.0	95.0	2.9	715
PLSRPM 315 LD1	-	315	96.6	MD2 400T	250	1590	1190	2160	1.36	1860	490	1.44	3.0	95.0	2.9	715
				MD2 400T	308	1960	1500	2240	1.14	2060	650 (665)	1.17	3.0	94.7	2.59	852
PLSRPM 315 LD1	-	355	96.8	MD2 470T	315	2010	1500	2680	1.34	2320	665	1.41	3.0	94.7	2.59	852
				MD2 470T	355	2260	1700	2660	1.18	2420	770	1.22	3.0	94.9	2.98	875
				MD2 570T	355	2260	1700	2920	1.29	2560	770	1.36	3.0	94.9	2.98	875
				MD2 600T	355	2260	1700	3100	1.37	2650	770	1.45	3.0	94.9	2.98	875

(1) See the Maximum torque curve in the Introduction, Selected method section.

(2) The maximum torque decreases from 80% of the rated speed to the value indicated at the rated speed.

(3) Motors and Drives rated current. If the motor rated current is higher, its value is indicated in brackets. The motor rated current must be entered in the drive.

(4) Minimum switching frequency. This value must be entered in the drive. Automatic changing of the switching frequency must be disabled.

(5) Motors with standard IEC mechanical dimensions (frame size, shaft extension)

Class F - DT80K - S1 Self-Cooled - Altitude 1000 m max - Ambient temperature 40°C max

Power supply upstream from the 400 V drive

110 Drive limit

115 Motor limit

Motor			Motors & Drives											Motor	
Motor type	Rated power	Efficiency IEC 60034-2-1	Type of Powerdrive MD2/FX	Available power	Rated torque	Sensorless starting torque	Maximum torque	Max. torque /Rated torque	Maximum torque at rated speed	Rated current	Max. current / Rated current	Minimum switching frequency	Motor-drive efficiency	Moment of inertia	Weight
	Pr (kW)	η 4/4		Pn (kW)	Tr (N.m)	75% Tr (N.m)	Tmax (N.m) ⁽¹⁾	Tmax/Tr	(N.m) ⁽²⁾	Ir (A) ⁽³⁾	I _{max} /I _r	Fs (kHz) ⁽⁴⁾	η 4/4	J (kg.m ²)	IM B3 (kg)
LSRPM 160 MP	18.7	93.5	FX 33T	18.7	99.2	74.4	136	1.37	117	36	1.45	4.0	91.6	0.0418	60
LSRPM 160 MP	23	94.0	FX 33T	23.0	122	91.5	167	1.37	143	42.9	1.45	4.0	92.1	0.0514	69
LSRPM 160 LR	27.3	94.0	FX 33T	27.3	145	109	172	1.19	156	52	1.23	4.0	92.1	0.0626	79
			FX 40T	27.3	145	109	199	1.37	170	52	1.45	4.0	92.1	0.0626	79
LSRPM 200 L	33	94.0	FX 40T	30.5	162	131	176	1.09	166	73 (79)	1.08	4.0	92.1	0.13	135
			FX 50T	30.5	162	131	231	1.43	195	73 (79)	1.51	4.0	92.1	0.13	135
			FX 60T	33	175	131	240	1.37	206	79	1.45	4.0	92.1	0.13	135
			MD2 60T	33	175	131	240	1.37	206	79	1.45	3.0	92.1	0.13	135
LSRPM 200 L	40	94.8	FX 50T	40	212	159	240	1.13	222	82.5	1.15	4.0	92.9	0.17	150
			FX 60T	40	212	159	289	1.36	248	82.5	1.44	4.0	92.9	0.17	150
			MD2 60T	40	212	159	291	1.37	249	82.5	1.45	3.0	92.9	0.17	150
LSRPM 200 L	55	95.7	MD2 60T	51.3	272	219	310	1.14	286	112 (120)	1.16	3.0	93.8	0.2	165
			FX 75T	55	292	219	363	1.24	323	120	1.31	4.0	93.8	0.2	165
			MD2 75T	55	292	219	380	1.30	332	120	1.38	3.0	93.8	0.2	165
			FX 100T	55	292	219	400	1.37	343	120	1.45	4.0	93.8	0.2	165
LSRPM 225 ST1	70	96.1	MD2 75T	68.6	364	279	414	1.14	382	142 (145)	1.16	3.0	94.2	0.26	193
			FX 75T	70	371	279	405	1.09	380	145	1.08	4.0	94.2	0.26	193
			FX 100T	70	371	279	461	1.24	411	145	1.30	4.0	94.2	0.26	193
			MD2 100T	70	371	279	485	1.31	423	145	1.38	3.0	94.2	0.26	193
LSRPM 225 MR1	85	96.0	MD2 120T	70	371	279	509	1.37	436	145	1.45	3.0	94.2	0.26	193
			FX 100T	85	451	338	496	1.10	464	172	1.10	4.0	94.1	0.32	223
			MD2 100T	85	451	338	514	1.14	474	172	1.16	3.0	94.1	0.32	223
LSRPM 250 ME	100	96.1	MD2 120T	85	451	338	595	1.32	517	172	1.40	3.0	94.1	0.32	223
			MD2 150T	100	531	398	609	1.15	560	204	1.18	3.0	94.2	0.65	285
LSRPM 280 SC	125	96.3	MD2 150T	100	531	398	727	1.37	623	204	1.45	3.0	94.2	0.65	285
			MD2 180T	125	663	497	800	1.21	721	248	1.26	3.0	94.4	0.84	330
LSRPM 280 SD	150	96.4	MD2 180T	125	663	497	909	1.37	779	248	1.45	3.0	94.4	0.84	330
			MD2 180T	150	796	597	948	1.19	858	295	1.24	3.0	94.5	1	380
			MD2 220T	150	796	597	1090	1.37	934	295	1.45	3.0	94.5	1	380
LSRPM 280 MK1	175	96.5	MD2 180T	167	886	696	1010	1.14	930	315 (330)	1.16	3.0	94.6	1.8	568
			MD2 220T	175	928	696	1160	1.25	1030	330	1.32	3.0	94.6	1.8	568
			MD2 270T	175	928	696	1270	1.37	1090	330	1.45	3.0	94.6	1.8	568
LSRPM 315 SP1	195	96.7	MD2 220T	195	1030	776	1190	1.15	1090	370	1.18	3.0	94.8	2.24	635
			MD2 270T	195	1030	776	1400	1.35	1210	370	1.43	3.0	94.8	2.24	635
LSRPM 315 MR1	230	96.9	MD2 220T	217	1150	915	1250	1.09	1180	400 (425)	1.09	3.0	95.0	2.7	720
			MD2 270T	230	1220	915	1460	1.20	1320	425	1.25	3.0	95.0	2.7	720
			MD2 340T	230	1220	915	1670	1.37	1430	425	1.45	3.0	95.0	2.7	720
LSRPM 315 MR1	300	96.5	MD2 340T	300	1590	1190	1790	1.12	1660	580	1.14	3.0	94.6	2.9	715
			MD2 400T	300	1590	1190	1980	1.24	1760	580	1.31	3.0	94.6	2.9	715
PLSRPM 315 LD1	355	96.8	MD2 470T	355	1880	1410	2280	1.21	2050	745	1.26	3.0	94.9	2.59	852
			MD2 570T	355	1880	1410	2510	1.33	2170	745	1.41	3.0	94.9	2.59	852
PLSRPM 315 LD1	400	96.9	MD2 470T	379	2010	1590	2300	1.14	2120	800 (845)	1.18	3.0	95.0	2.98	875
			MD2 570T	400	2120	1590	2530	1.19	2290	845	1.24	3.0	95.0	2.98	875
			MD2 600T	400	2120	1590	2870	1.35	2470	845	1.43	3.0	95.0	2.98	875

(1) See the Maximum torque curve in the Introduction, Selected method section.

(2) The maximum torque decreases from 80% of the rated speed to the value indicated at the rated speed.

(3) Motors and Drives rated current. If the motor rated current is higher, its value is indicated in brackets. The motor rated current must be entered in the drive.

(4) Minimum switching frequency. This value must be entered in the drive. Automatic changing of the switching frequency must be disabled.

Class F - DT80K - S1 Self-Cooled - Altitude 1000 m max - Ambient temperature 40°C max

Power supply upstream from the 400 V drive

100	Drive limit
110	Motor limit

Motor			Motors & Drives											Motor	
Motor type	Rated power	Efficiency IEC 60034-2-1	Type of Powerdrive MD2/FX	Available power	Rated torque	Sensorless starting torque	Maximum torque	Max. torque /Rated torque	Maximum torque at rated speed	Rated current	Max. current / Rated current	Minimum switching frequency	Motor-drive efficiency	Moment of inertia	Weight
	Pr (kW)	η 4/4		Pn (kW)	Tr (N.m)	75% Tr (N.m)	Tmax (N.m) ⁽¹⁾	Tmax/Tr	(N.m) ⁽²⁾	Ir (A) ⁽³⁾	Imax/Ir	Fs (kHz) ⁽⁴⁾	η 4/4	J (kg.m ²)	IM B3 (kg)
LSRPM 160 LR	36	94.5	MD2 60T	36	143	107	196	1.37	168	69	1.45	8.0	92.6	0.0626	79
			FX 60T	50	199	149	217	1.09	204	110	1.08	4.0	93.5	0.17	150
LSRPM 200 L	50	95.4	MD2 60T	50	199	149	229	1.15	210	110	1.18	4.0	93.5	0.17	150
			FX 75T	50	199	149	268	1.35	231	110	1.43	4.0	93.5	0.17	150
			MD2 75T	50	199	149	273	1.37	234	110	1.45	4.0	93.5	0.17	150
			MD2 75T	63.1	251	194	300	1.19	271	133 (137)	1.24	4.0	94.0	0.2	168
LSRPM 200 L1	65	95.9	FX 75T	65	259	194	292	1.13	270	137	1.15	4.0	94.0	0.2	168
			FX 100T	65	259	194	338	1.31	295	137	1.38	4.0	94.0	0.2	168
			MD2 100T	65	259	194	354	1.37	304	137	1.45	4.0	94.0	0.2	168
			FX 100T	80	318	239	366	1.15	337	160	1.18	4.0	94.7	0.24	183
LSRPM 200 L1	80	96.6	MD2 100T	80	318	239	382	1.20	345	160	1.25	4.0	94.7	0.24	183
			MD2 120T	80	318	239	436	1.37	374	160	1.45	4.0	94.7	0.24	183
LSRPM 225 MR1	100	96.9	MD2 120T	94	374	298	456	1.22	409	188 (200)	1.28	4.0	95.0	0.3	218
			MD2 150T	100	398	298	545	1.37	467	200	1.45	4.0	95.0	0.3	218
LSRPM 250 SE	125	97.2	MD2 150T	119	474	373	625	1.32	543	224 (235)	1.39	4.0	95.3	0.65	285
			MD2 180T	125	497	373	682	1.37	584	235	1.45	4.0	95.3	0.65	285
LSRPM 250 ME	150	97.3	MD2 180T	150	597	448	730	1.22	654	285	1.28	4.0	95.4	0.75	310
			MD2 220T	150	597	448	818	1.37	701	285	1.45	4.0	95.4	0.75	310
LSRPM 280 SD1	190	97.5	MD2 220T	190	756	567	903	1.19	817	350	1.24	4.0	95.6	1	383
			MD2 270T	190	756	567	1040	1.38	888	350	1.45	4.0	95.6	1	383
LSRPM 280 MK1	230	97.4	MD2 270T	230	915	686	1090	1.19	986	429	1.24	4.0	95.5	1.9	591
			MD2 340T	230	915	686	1250	1.37	1070	429	1.45	4.0	95.5	1.9	591
LSRPM 315 SP1	285	97.6	MD2 340T	285	1130	851	1400	1.23	1250	509	1.30	4.0	95.6	2.5	675
			MD2 400T	285	1130	851	1550	1.37	1330	509	1.45	4.0	95.6	2.5	675
LSRPM 315 SR1	310	97.7	MD2 340T	293	1170	925	1410	1.21	1270	525 (555)	1.26	4.0	95.7	2.6	715
			MD2 400T	310	1230	925	1600	1.30	1400	555	1.37	4.0	95.7	2.6	715
			MD2 470T	310	1230	925	1690	1.37	1450	555	1.45	4.0	95.7	2.6	715
LSRPM 315 MR1	350	97.5	MD2 400T	328	1310	1040	1570	1.20	1420	605 (645)	1.26	4.0	95.6	2.7	720
			MD2 470T	350	1390	1040	1910	1.37	1630	645	1.45	4.0	95.6	2.7	720

(1) See the Maximum torque curve in the Introduction, Selected method section.

(2) The maximum torque decreases from 80% of the rated speed to the value indicated at the rated speed.

(3) Motors and Drives rated current. If the motor rated current is higher, its value is indicated in brackets. The motor rated current must be entered in the drive.

(4) Minimum switching frequency. This value must be entered in the drive. Automatic changing of the switching frequency must be disabled.

Class F - DT80K - S1 Self-Cooled - Altitude 1000 m max - Ambient temperature 40°C max

Power supply upstream from the 400 V drive

157 Drive limit

170 Motor limit

Motor			Motors & Drives											Motor	
Motor type	Rated power	Efficiency IEC 60034-2-1	Type of Powerdrive MD2/FX	Available power	Rated torque	Sensorless starting torque	Maximum torque	Max. torque /Rated torque	Maximum torque at rated speed	Rated current	Max. current / Rated current	Minimum switching frequency	Motor-drive efficiency	Moment of inertia	Weight
	Pr (kW)	η 4/4		Pn (kW)	Tr (N.m)	75% Tr (N.m)	Tmax (N.m) ⁽¹⁾	Tmax/Tr	(N.m) ⁽²⁾	Ir (A) ⁽³⁾	I _{max} /I _r	F _s (kHz) ⁽⁴⁾	η 4/4	J (kg.m ²)	IM B3 (kg)
LSRPM 160 MP	37	95.0	MD2 60T	37	118	88.4	162	1.38	139	67.8	1.45	8.0	93.1	0.0514	69
LSRPM 160 LR	44	95.0	MD2 60T	44	140	105	192	1.37	165	82	1.45	8.0	93.1	0.0626	79
LSRPM 200 L	50	95.2	FX 60T	49.8	159	119	173	1.09	162	110 (110.5)	1.08	4.0	93.3	0.13	135
			MD2 60T	50	159	119	183	1.15	168	110.5	1.18	4.0	93.3	0.13	135
			FX 75T	50	159	119	214	1.34	185	110.5	1.42	4.0	93.3	0.13	135
			MD2 75T	50	159	119	218	1.37	187	110.5	1.45	4.0	93.3	0.13	135
LSRPM 200 L1	65	96.0	FX 75T	65	207	155	248	1.20	224	125.9	1.25	4.0	94.1	0.17	153
			MD2 75T	65	207	155	258	1.25	229	125.9	1.31	4.0	94.1	0.17	153
			FX 100T	65	207	155	284	1.37	243	125.9	1.45	4.0	94.1	0.17	153
LSRPM 200 L1	85	96.5	FX 100T	85	271	203	300	1.11	280	170	1.11	4.0	94.6	0.22	178
			MD2 120T	85	271	203	361	1.33	313	170	1.41	4.0	94.6	0.22	178
LSRPM 225 ST2	110	96.6	MD2 150T	110	350	263	480	1.37	411	215	1.45	4.0	94.7	0.24	195
LSRPM 250 SE	145	97.1	MD2 180T	145	462	346	565	1.22	506	284.7	1.28	4.0	95.2	0.57	265
			MD2 220T	145	462	346	633	1.37	542	284.7	1.45	4.0	95.2	0.57	265
LSRPM 250 ME1	170	97.2	MD2 220T	170	541	406	665	1.23	594	338	1.29	4.0	95.3	0.65	288
			MD2 270T	170	541	406	742	1.37	635	338	1.45	4.0	95.3	0.65	288
			MD2 220T	200	637	477	737	1.16	675	365	1.19	4.0	95.4	0.84	333
LSRPM 280 SD1	200	97.3	MD2 270T	200	637	477	873	1.37	747	365	1.45	4.0	95.4	0.84	333
			MD2 220T	220	700	525	804	1.15	739	370	1.18	4.0	95.5	1	383
LSRPM 280 SD1	220	97.4	MD2 270T	220	700	525	948	1.35	816	370	1.43	4.0	95.5	1	383
			MD2 270T	243	775	621	904	1.17	826	440 (470)	1.20	4.0	95.5	2.1	620
LSRPM 280 MK1	260	97.4	MD2 340T	260	828	621	1100	1.33	953	470	1.40	4.0	95.5	2.1	620
			MD2 340T	287	914	692	1100	1.20	993	525 (530)	1.26	4.0	95.5	2.1	620
LSRPM 280 MK1	290	97.4	MD2 400T	290	923	692	1250	1.35	1080	530	1.43	4.0	95.5	2.1	620
			MD2 400T	320	1020	764	1260	1.24	1120	585.7	1.30	4.0	95.6	2.5	670
LSRPM 315 SP1	320	97.5	MD2 470T	320	1020	764	1390	1.36	1190	585.7	1.45	4.0	95.6	2.5	670
			MD2 470T	355	1130	848	1530	1.35	1320	655	1.44	4.0	95.5	2.33	837
PLSRPM 315 LD1	400	97.4	MD2 470T	397	1260	955	1560	1.23	1390	725 (730)	1.30	4.0	95.5	2.59	860
			MD2 570T	400	1270	955	1730	1.36	1490	730	1.44	4.0	95.5	2.59	860
PLSRPM 315 LD1	450	97.5	MD2 600T	450	1430	1070	1930	1.35	1660	850	1.42	4.0	95.6	2.98	883
			MD2 600T	500	1590	1190	1940	1.22	1740	950	1.27	4.0	95.6	2.98	883
PLSRPM 315 LD1	500	97.6	MD2 750T	500	1590	1190	2180	1.37	1870	950	1.45	4.0	95.6	2.98	883

(1) See the Maximum torque curve in the Introduction, Selected method section.

(2) The maximum torque decreases from 80% of the rated speed to the value indicated at the rated speed.

(3) Motors and Drives rated current. If the motor rated current is higher, its value is indicated in brackets. The motor rated current must be entered in the drive.

(4) Minimum switching frequency. This value must be entered in the drive. Automatic changing of the switching frequency must be disabled.

Class F - DT80K - S1 Self-Cooled - Altitude 1000 m max - Ambient temperature 40°C max

Power supply upstream from the 400 V drive

126 Drive limit

130 Motor limit

Motor			Motors & Drives											Motor	
Motor type	Rated power	Efficiency IEC 60034-2-1	Type of Powerdrive MD2/FX	Available power	Rated torque	Sensorless starting torque	Maximum torque	Max. torque /Rated torque	Maximum torque at rated speed	Rated current	Max. current / Rated current	Minimum switching frequency	Motor-drive efficiency	Moment of inertia	Weight
	Pr (kW)	η 4/4		Pn (kW)	Tr (N.m)	75% Tr (N.m)	Tmax (N.m) ⁽¹⁾	Tmax/Tr	(N.m) ⁽²⁾	Ir (A) ⁽³⁾	I _{max} /I _r	Fs (kHz) ⁽⁴⁾	η 4/4	J (kg.m ²)	IM B3 (kg)
LSRPM 160 MP	34	95.0	MD2 60T	34	90.2	68	124	1.37	106	63	1.45	8.0	93.1	0.0418	60
LSRPM 160 MP	41	95.5	MD2 60T	41	109	82	149	1.37	128	77	1.45	8.0	93.6	0.0514	69
LSRPM 160 LR	49	95.5	MD2 60T	45.8	121	98	176	1.45	148	85 (91)	1.53	8.0	93.6	0.0626	79
			MD2 75T	49	130	98	178	1.37	153	91	1.45	8.0	93.6	0.0626	79
LSRPM 200 L1	70	96.0	FX 75T	70	186	139	219	1.18	199	128.6	1.22	4.0	94.1	0.17	153
			MD2 75T	70	186	139	228	1.23	204	128.6	1.28	4.0	94.1	0.17	153
			FX 100T	70	186	139	255	1.37	218	128.6	1.45	4.0	94.1	0.17	153
			MD2 100T	70	186	139	255	1.37	218	128.6	1.45	4.0	94.1	0.17	153
LSRPM 200 L1	85	96.4	FX 100T	85	226	169	258	1.14	237	161.9	1.17	4.0	94.5	0.22	178
			MD2 120T	85	226	169	309	1.37	265	161.9	1.45	4.0	94.5	0.22	178
LSRPM 200 LU2	115	96.8	MD2 150T	115	305	229	410	1.34	354	217.4	1.42	4.0	94.9	0.26	195
LSRPM 225 SG	132	96.8	MD2 180T	132	350	263	480	1.37	411	250	1.45	4.0	94.9	0.54	250
LSRPM 250 SE1	165	96.9	MD2 180T	155	411	328	472	1.15	434	310 (330)	1.18	4.0	95.0	0.57	268
			MD2 220T	165	438	328	549	1.25	487	330	1.32	4.0	95.0	0.57	268
LSRPM 250 SE1	190	97.1	MD2 220T	190	504	378	602	1.19	545	350	1.24	4.0	95.2	0.65	288
			MD2 270T	190	504	378	691	1.37	592	350	1.45	4.0	95.2	0.65	288
LSRPM 280 SD1	240	97.1	MD2 270T	240	637	477	770	1.21	693	420	1.26	4.0	95.2	1	383
			MD2 340T	240	637	477	832	1.31	726	420	1.38	4.0	95.2	1	383
LSRPM 280 MK1	270	97.2	MD2 340T	270	716	537	932	1.30	815	480	1.38	4.0	95.3	2.1	620
			MD2 400T	270	716	537	982	1.37	841	480	1.45	4.0	95.3	2.1	620
PLSRPM 315 LD1	315	97.1	MD2 340T	306	812	627	979	1.21	882	525 (540)	1.26	4.0	95.2	2.33	837
			MD2 400T	315	836	627	1110	1.33	963	540	1.41	4.0	95.2	2.33	837
PLSRPM 315 LD1	355	97.2	MD2 400T	330	877	706	1060	1.21	952	605 (650)	1.26	4.0	95.3	2.33	837
			MD2 470T	355	942	706	1290	1.37	1100	650	1.45	4.0	95.3	2.33	837
PLSRPM 315 LD1	400	97.3	MD2 470T	400	1060	796	1310	1.23	1170	725	1.30	4.0	95.4	2.59	860
			MD2 570T	400	1060	796	1450	1.37	1240	725	1.45	4.0	95.4	2.59	860
PLSRPM 315 LD1	450	97.5	MD2 570T	422	1120	895	1480	1.32	1290	750 (800)	1.40	4.0	95.6	2.98	883
			MD2 600T	450	1190	895	1640	1.37	1400	800	1.45	4.0	95.6	2.98	883
PLSRPM 315 LD1	500	97.6	MD2 600T	500	1330	995	1730	1.30	1510	880	1.38	4.0	95.6	2.98	883
			MD2 750T	500	1330	995	1820	1.37	1560	880	1.45	4.0	95.6	2.98	883

(1) See the Maximum torque curve in the Introduction, Selected method section.

(2) The maximum torque decreases from 80% of the rated speed to the value indicated at the rated speed.

(3) Motors and Drives rated current. If the motor rated current is higher, its value is indicated in brackets. The motor rated current must be entered in the drive.

(4) Minimum switching frequency. This value must be entered in the drive. Automatic changing of the switching frequency must be disabled.

Class F - DT80K - S1 Self-Cooled - Altitude 1000 m max - Ambient temperature 40°C max

Power supply upstream from the 400 V drive

92 Drive limit

97 Motor limit

Motor			Motors & Drives											Motor	
Motor type	Rated power	Efficiency IEC 60034-2-1	Type of Powerdrive MD2/FX	Available power	Rated torque	Sensorless starting torque	Maximum torque	Max. torque /Rated torque	Maximum torque at rated speed	Rated current	Max. current / Rated current	Minimum switching frequency	Motor-drive efficiency	Moment of inertia	Weight
	Pr (kW)	η 4/4		Pn (kW)	Tr (N.m)	75% Tr (N.m)	Tmax (N.m) ⁽¹⁾	Tmax/Tr	(N.m) ⁽²⁾	Ir (A) ⁽³⁾	Imax/Ir	Fs (kHz) ⁽⁴⁾	η 4/4	J (kg.m ²)	IM B3 (kg)
LSRPM 160 MP	35	95.0	MD2 60T	35	74.3	55.7	102	1.37	87.3	67	1.45	8.0	93.1	0.0418	60
LSRPM 160 MP	44	95.5	MD2 60T	44	93.4	70.0	128	1.37	110	81	1.45	8.0	93.6	0.0514	69
LSRPM 160 LR	52	95.5	MD2 75T	49.3	105	82.7	152	1.45	127	92 (97)	1.53	8.0	93.6	0.0626	79
			MD2 100T	52	110	82.7	151	1.37	130	97	1.45	8.0	93.6	0.0626	79
LSRPM 200 L1	65	95.3	FX 75T	65	138	103	161	1.17	147	130	1.21	5.0	93.4	0.13	138
			FX 100T	65	138	103	189	1.37	162	130	1.45	5.0	93.4	0.13	138
			MD2 100T	65	138	103	189	1.37	162	130	1.45	5.0	93.4	0.13	138
LSRPM 200 L1	80	95.7	MD2 100T	74	157	127	201	1.28	177	148 (160)	1.35	5.0	93.8	0.15	148
			FX 100T	79	168	127	195	1.16	178	158 (160)	1.20	5.0	93.8	0.15	148
LSRPM 200 L1	100	96.2	MD2 120T	80	170	127	233	1.37	199	160	1.45	5.0	93.8	0.15	148
			MD2 150T	100	212	159	291	1.37	249	200	1.45	5.0	94.3	0.2	168
LSRPM 200 L2	120	96.4	MD2 180T	120	255	191	349	1.37	299	230	1.45	5.0	94.5	0.24	185
LSRPM 200 LU2	135	96.5	MD2 180T	135	287	215	383	1.34	331	258	1.41	5.0	94.6	0.26	195
LSRPM 225 SR2	150	96.6	MD2 180T	149	316	239	419	1.33	364	260 (262)	1.40	5.0	94.7	0.32	230
			MD2 180T	150	318	239	420	1.32	365	262	1.39	5.0	94.7	0.32	230
LSRPM 250 SE1	170	96.5	MD2 180T	170	361	271	448	1.24	399	280	1.30	5.0	94.6	0.76	310
			MD2 220T	170	361	271	495	1.37	424	280	1.45	5.0	94.6	0.76	310

(1) See the Maximum torque curve in the Introduction, Selected method section.

(2) The maximum torque decreases from 80% of the rated speed to the value indicated at the rated speed.

(3) Motors and Drives rated current. If the motor rated current is higher, its value is indicated in brackets. The motor rated current must be entered in the drive.

(4) Minimum switching frequency. This value must be entered in the drive. Automatic changing of the switching frequency must be disabled.

Class F - DT80K - S1 Self-Cooled - Altitude 1000 m max - Ambient temperature 40°C max

Power supply upstream from the 400 V drive

85	Drive limit
97	Motor limit

Motor			Motors & Drives											Motor	
Motor type	Rated power	Efficiency IEC 60034-2-1	Type of Powerdrive MD2/FX	Available power	Rated torque	Sensorless starting torque	Maximum torque	Max. torque /Rated torque	Maximum torque at rated speed	Rated current	Max. current / Rated current	Minimum switching frequency	Motor-drive efficiency	Moment of inertia	Weight
	Pr (kW)	η 4/4		Pn (kW)	Tr (N.m)	75% Tr (N.m)	Tmax (N.m) ⁽¹⁾	Tmax/Tr	(N.m) ⁽²⁾	Ir (A) ⁽³⁾	I _{max} /I _r	Fs (kHz) ⁽⁴⁾	η 4/4	J (kg.m ²)	IM B3 (kg)
LSRPM 160 MP	35	94.5	MD2 60T	35	60.8	45.6	83.4	1.37	71.4	67	1.45	8.0	92.6	0.0418	60
LSRPM 160 MP	44	95.0	MD2 60T	44	76.4	57.3	105	1.37	90	82	1.45	8.0	93.1	0.0514	69
LSRPM 160 LR	52	95.0	MD2 75T	49.3	85.6	67.7	124	1.45	104	92 (97)	1.53	8.0	93.1	0.0626	79
			MD2 100T	52	90.3	67.7	124	1.37	106	97	1.45	8.0	93.1	0.0626	79
LSRPM 200 L1	70	95.2	FX 100T	68.5	119	91.1	155	1.30	136	137 (140)	1.38	6.0	93.3	0.13	138
			MD2 100T	67	116	91.1	164	1.41	139	134 (140)	1.49	6.0	93.3	0.13	138
			MD2 120T	70	122	91.1	167	1.37	143	140	1.45	6.0	93.3	0.13	138
LSRPM 200 L1	85	95.4	MD2 150T	80	139	111	203	1.46	170	160 (170)	1.54	6.0	93.5	0.15	148
			MD2 150T	85	148	111	202	1.37	173	170	1.45	6.0	93.5	0.15	148
LSRPM 200 L1	100	95.8	MD2 180T	100	174	130	238	1.37	204	210	1.45	6.0	93.9	0.17	153
LSRPM 200 L2	140	96.6	MD2 180T	132	229	182	317	1.38	271	250 (264.9)	1.46	6.0	94.7	0.22	180
			MD2 180T	140	243	182	317	1.30	277	264.9	1.38	6.0	94.7	0.22	180

(1) See the Maximum torque curve in the Introduction, Selected method section.

(2) The maximum torque decreases from 80% of the rated speed to the value indicated at the rated speed.

(3) Motors and Drives rated current. If the motor rated current is higher, its value is indicated in brackets. The motor rated current must be entered in the drive.

(4) Minimum switching frequency. This value must be entered in the drive. Automatic changing of the switching frequency must be disabled.

Thermal torque (S1 duty without forced ventilation) and efficiency curves

Torque from 0 to 145 N.m

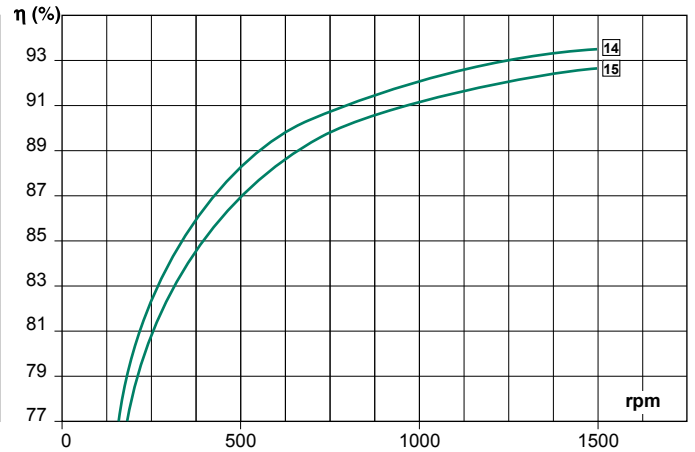
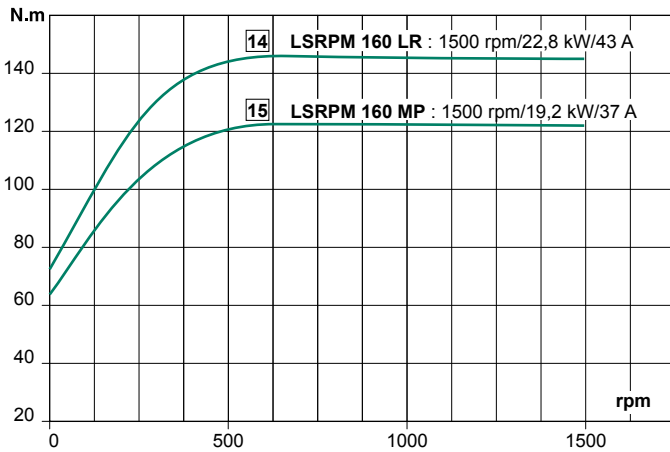

Torque from 145 to 350 N.m

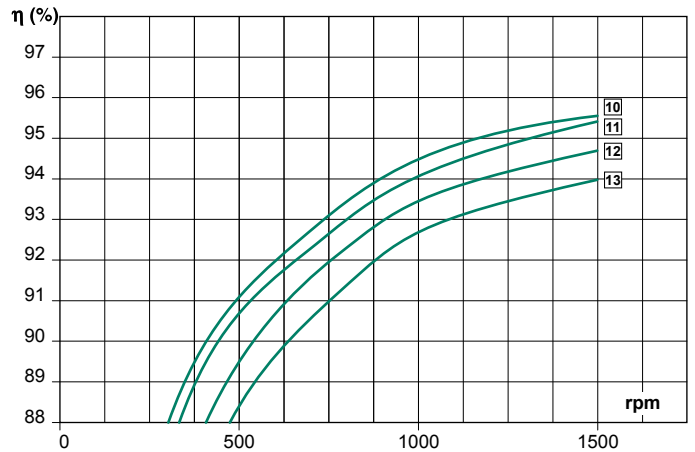
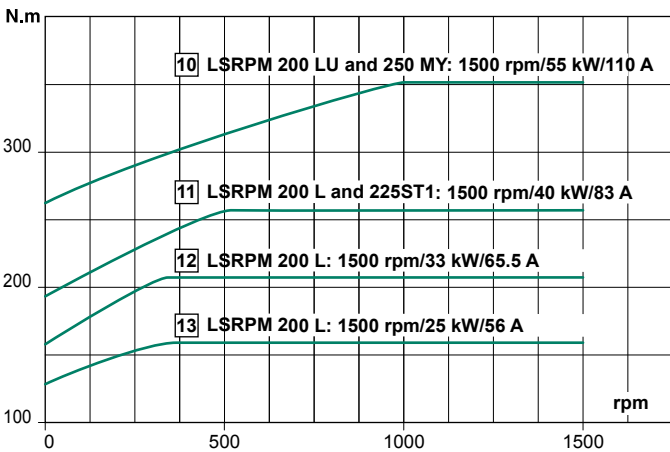

Torque from 350 to 800 N.m

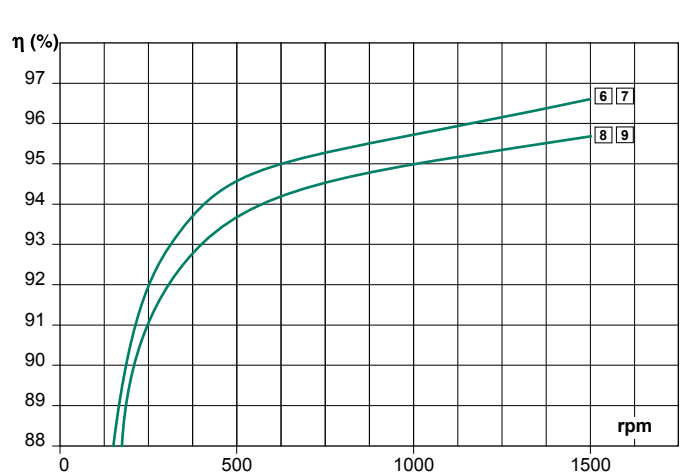
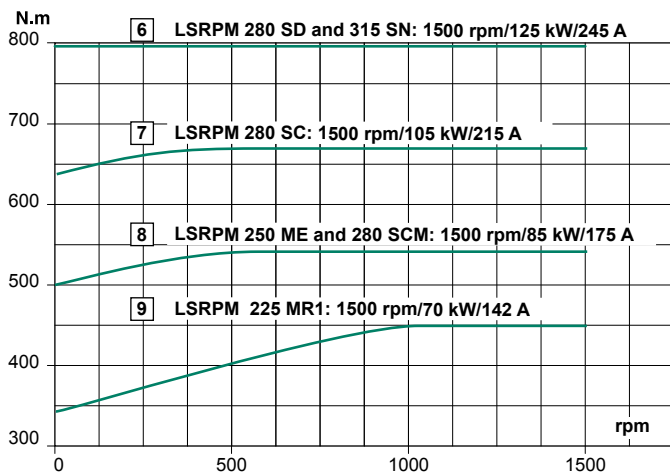

Thermal torque (S1 duty without forced ventilation) and efficiency curves

Torque from 800 to 1400 N.m

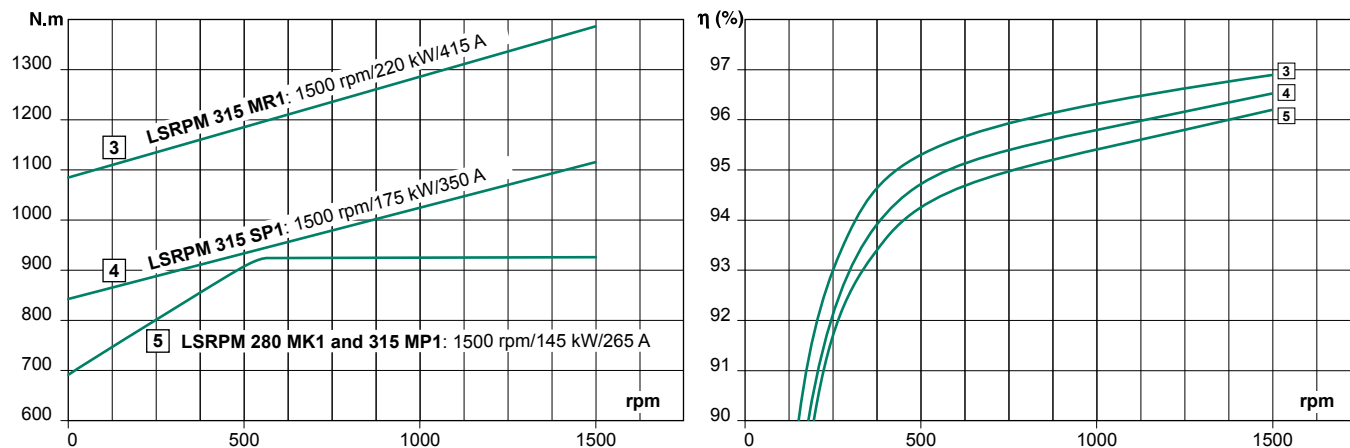

Torque from 1400 to 2300 N.m

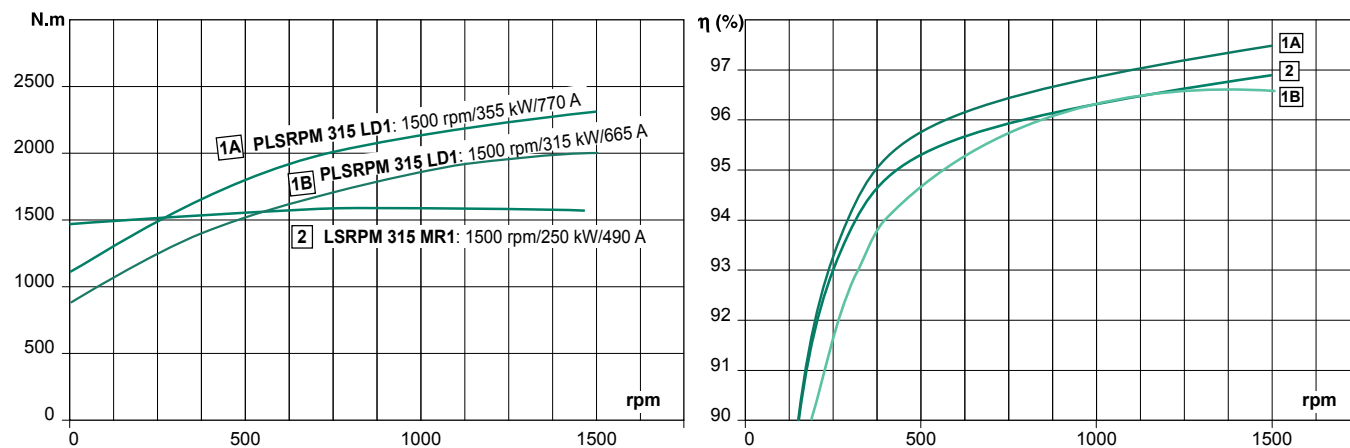

Thermal torque (S1 duty without forced ventilation) and efficiency curves

Torque from 0 to 145 N.m

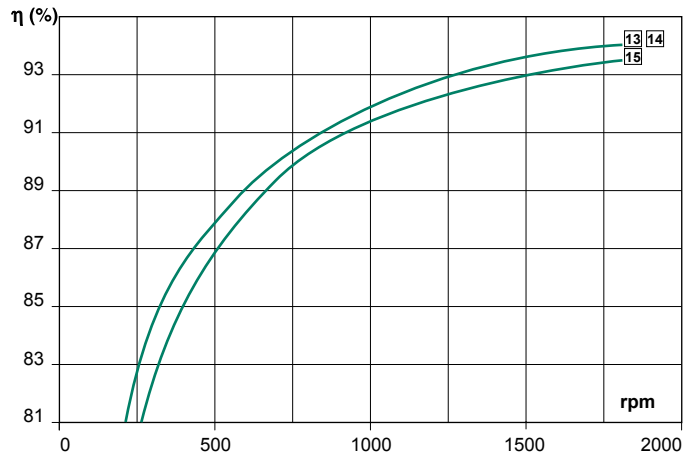
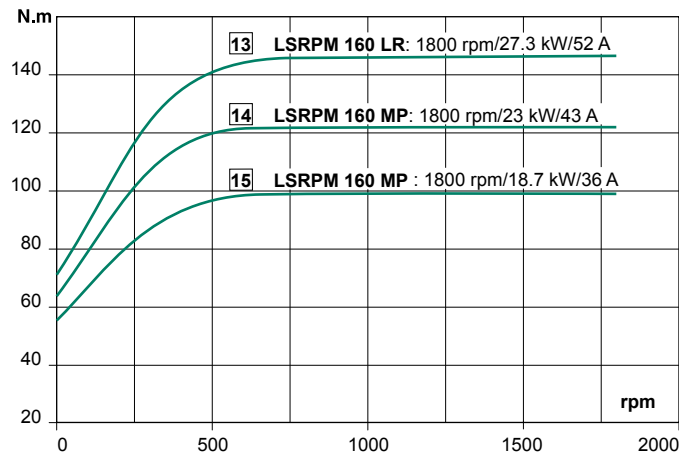

Torque from 145 to 450 N.m

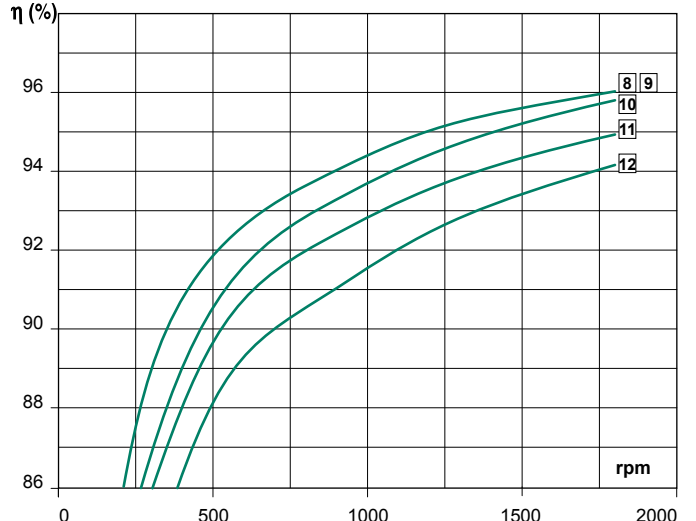
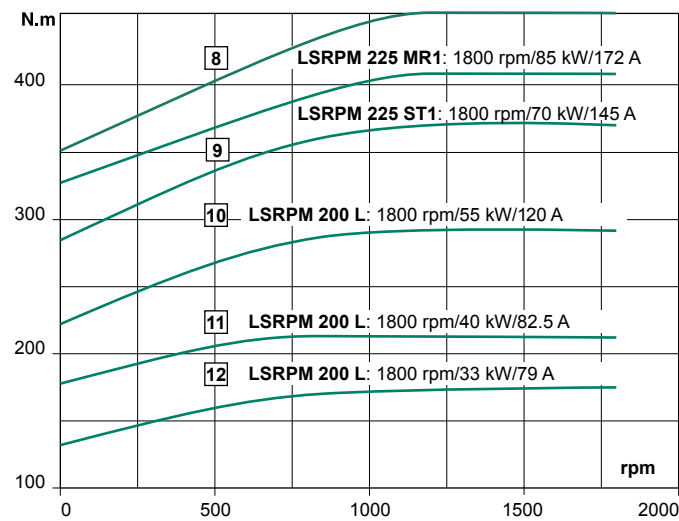

Torque from 450 to 800 N.m

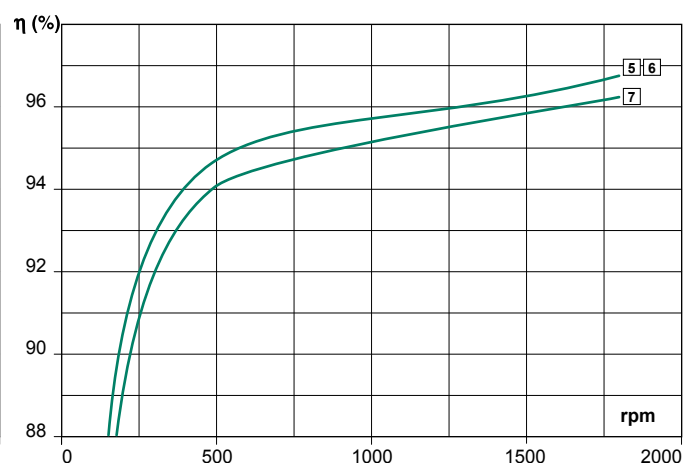
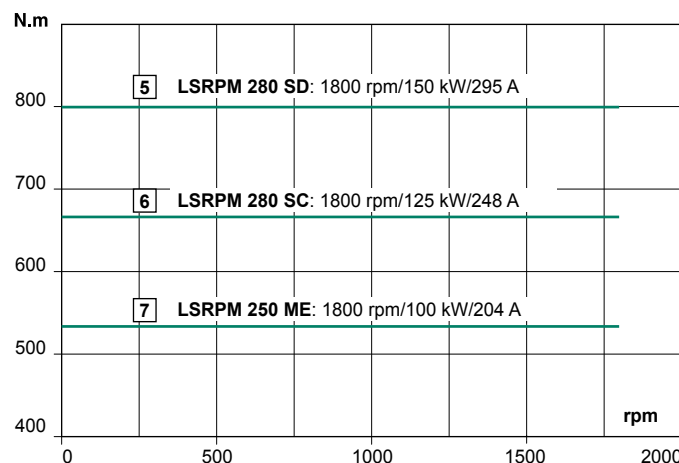

Thermal torque (S1 duty without forced ventilation) and efficiency curves

Torque from 800 to 1220 N.m

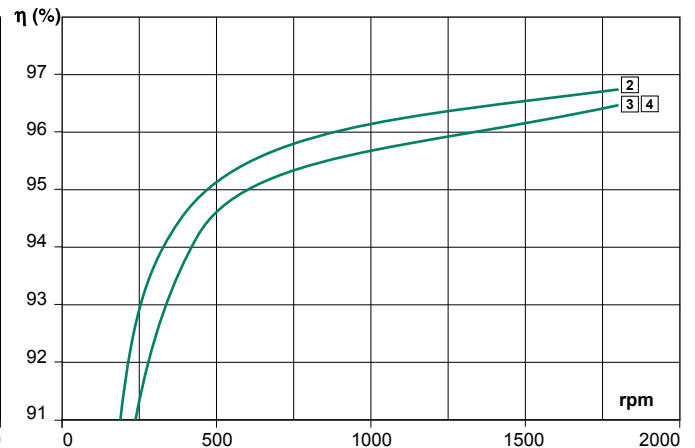
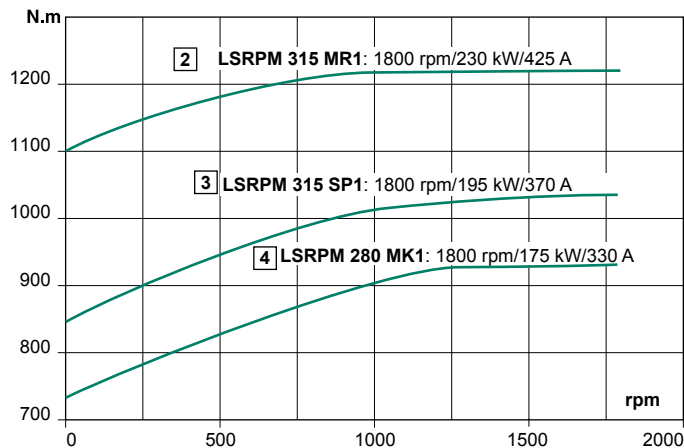

Torque from 1220 to 1650 N.m

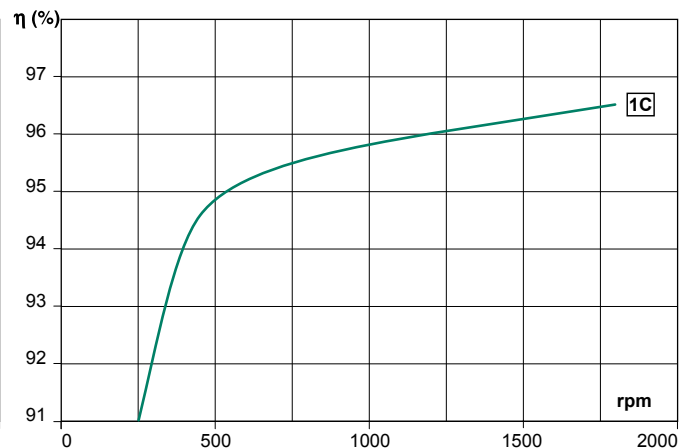
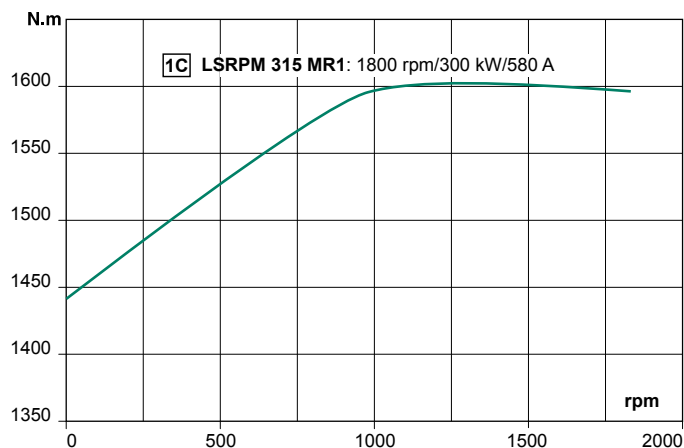

Torque from 1650 to 2300 N.m

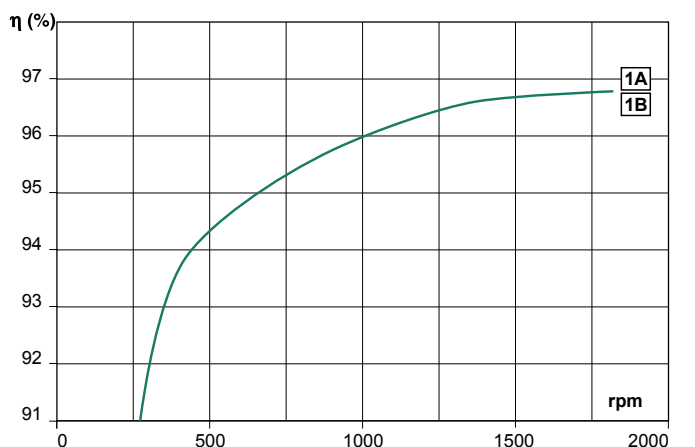
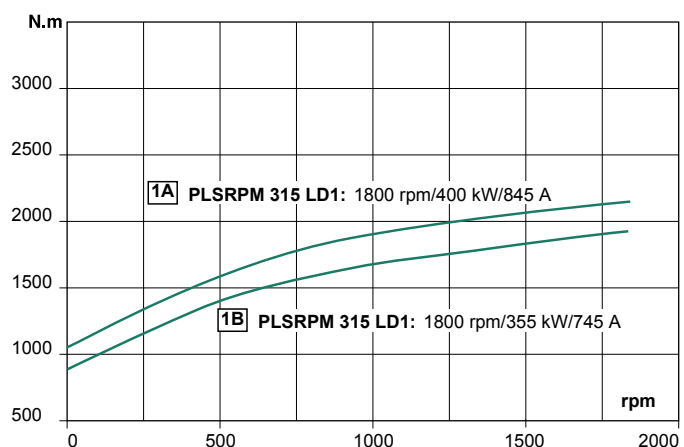

Thermal torque (S1 duty without forced ventilation) and efficiency curves

Torque from 0 to 145 N.m

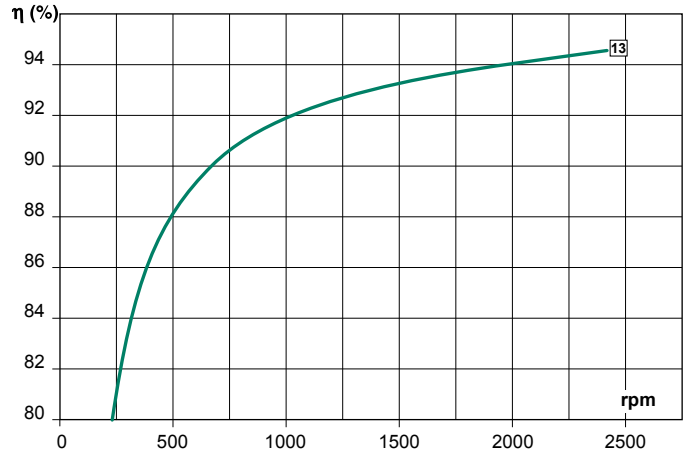
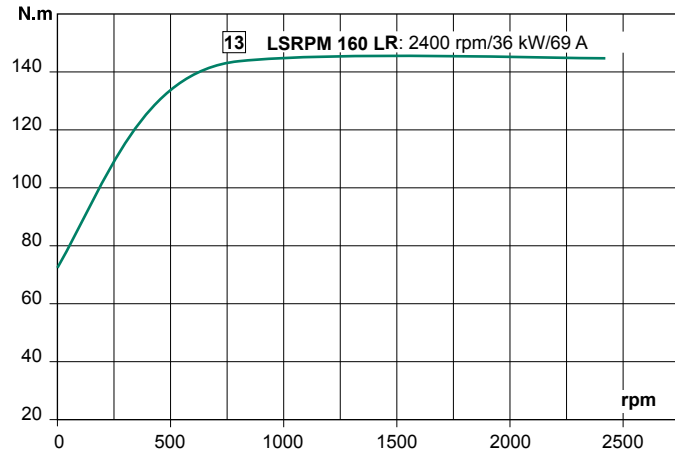

Torque from 145 to 400 N.m

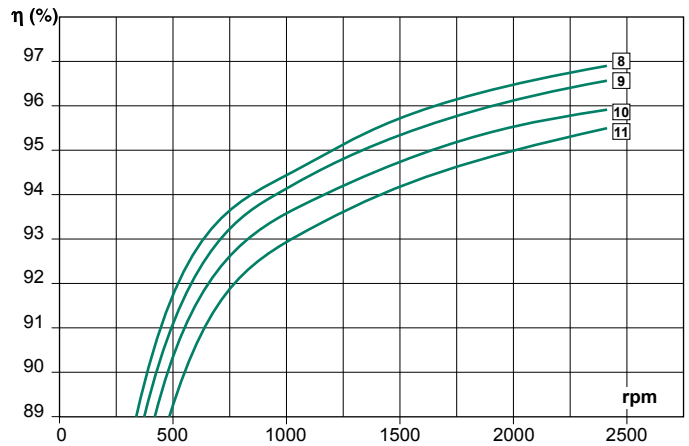
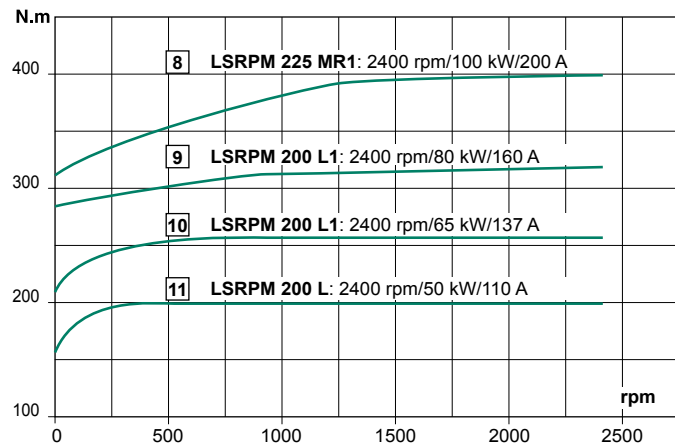

Thermal torque (S1 duty without forced ventilation) and efficiency curves

Torque from 400 to 755 N.m

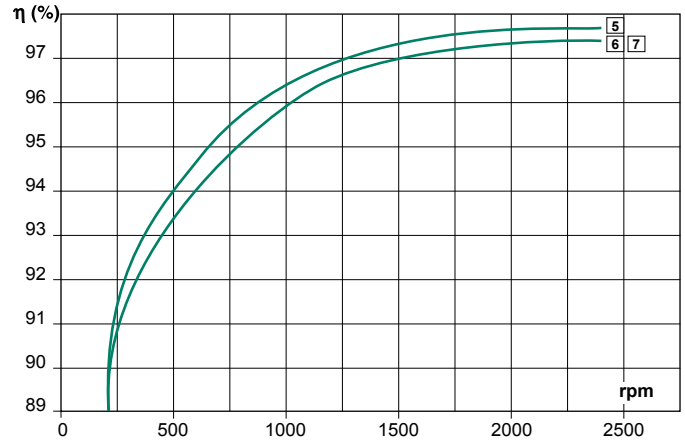
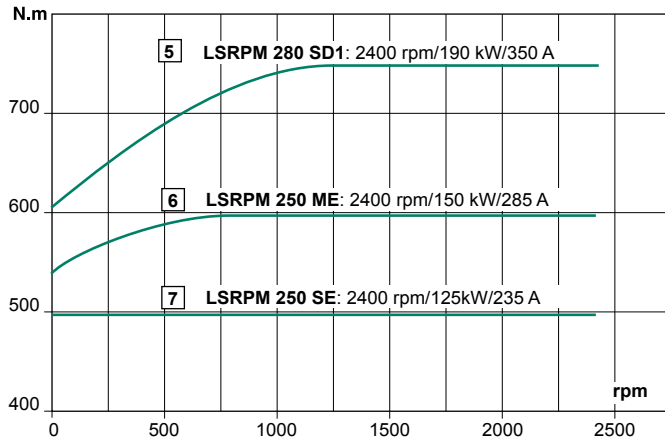

Torque from 755 to 1400 N.m

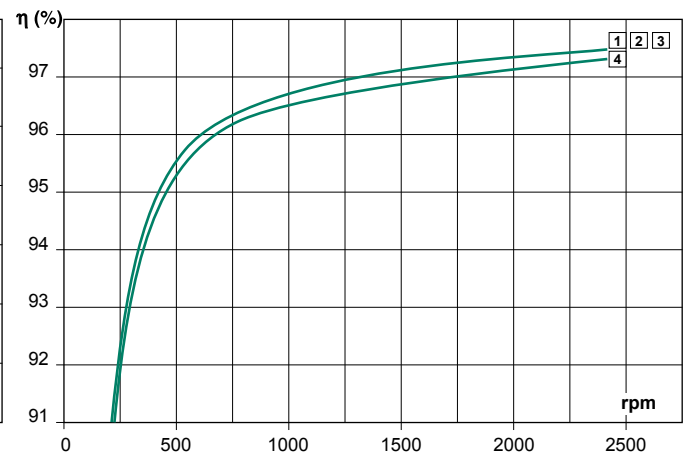
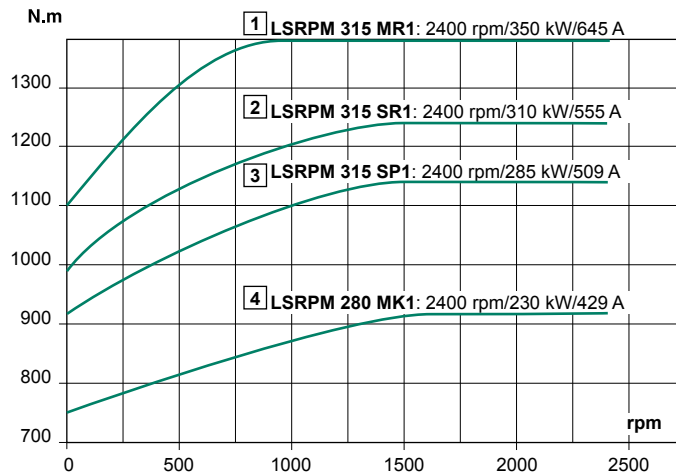

Thermal torque (S1 duty without forced ventilation) and efficiency curves

Torque from 0 to 140 N.m

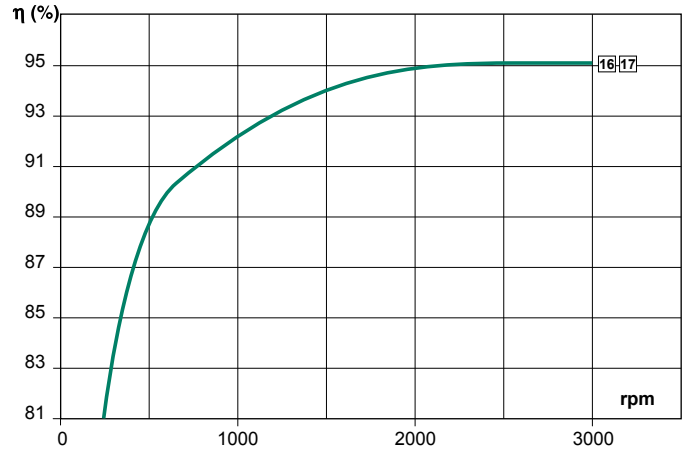
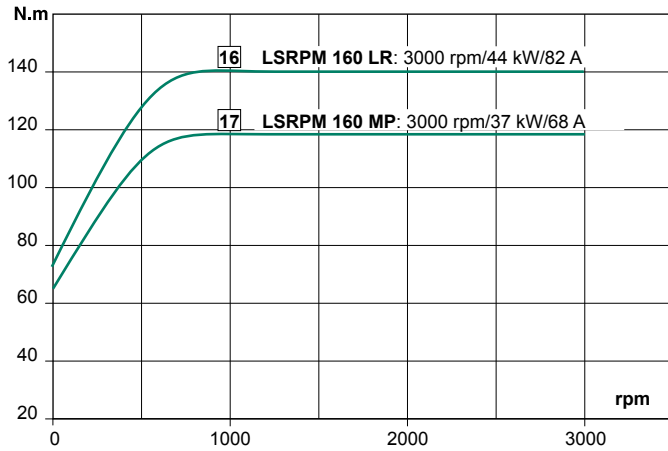

Torque from 140 to 350 N.m

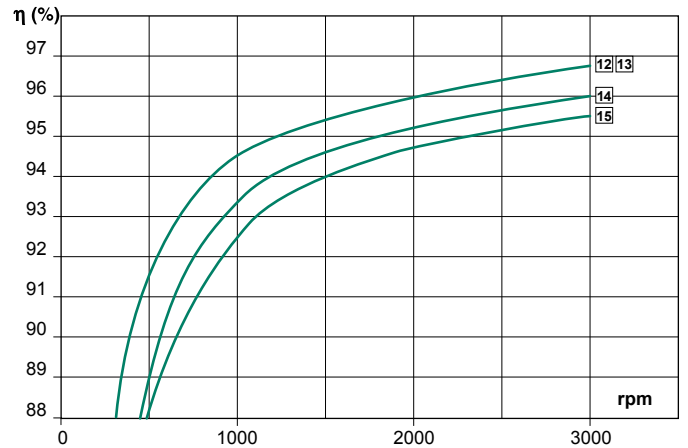
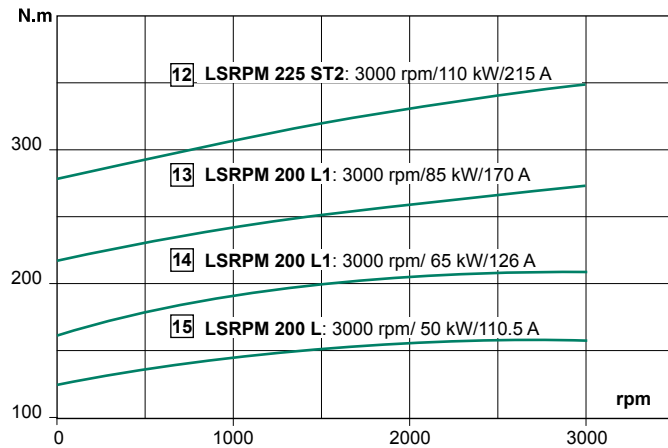

Thermal torque (S1 duty without forced ventilation) and efficiency curves

Torque from 350 to 700 N.m

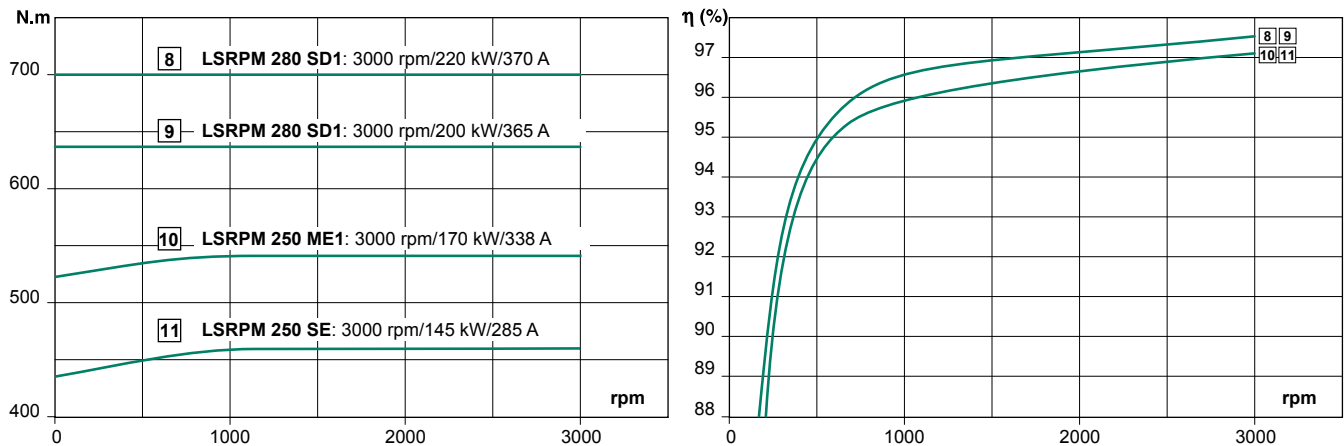

Torque from 700 to 1100 N.m

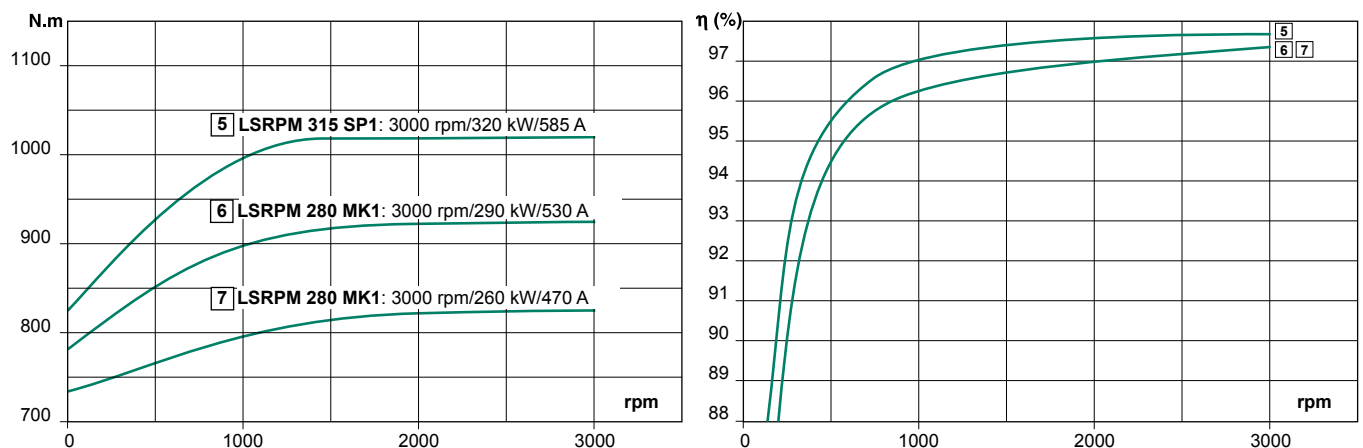

Torque from 1100 to 1600 N.m

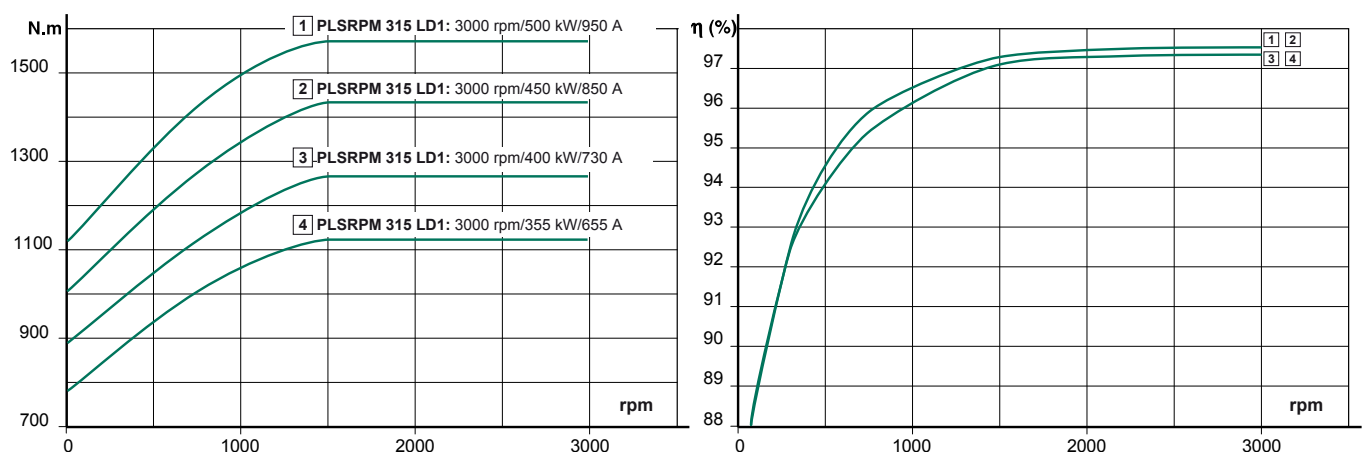

Thermal torque (S1 duty without forced ventilation) and efficiency curves

Torque from 0 to 130 N.m

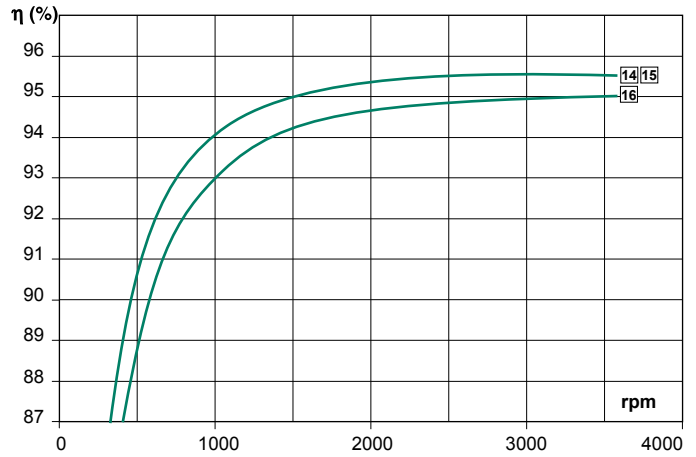
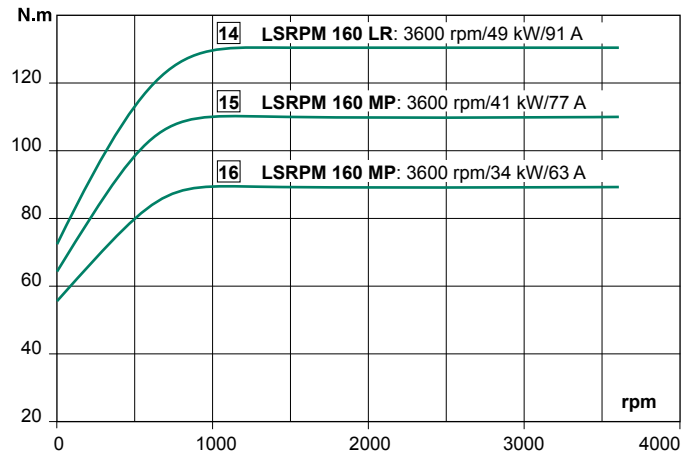

Torque from 130 to 305 N.m

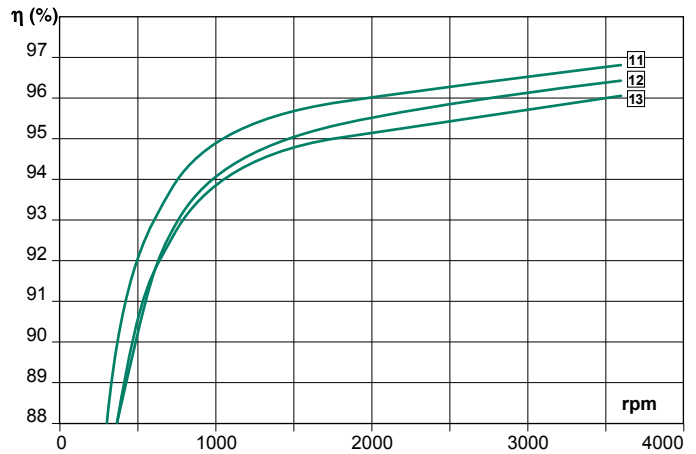
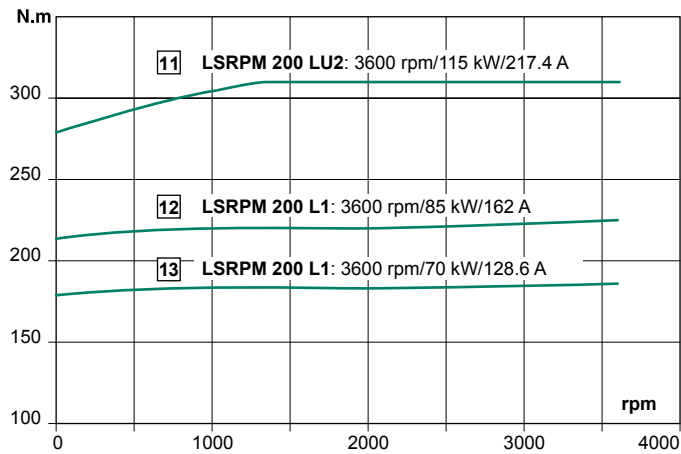

Thermal torque (S1 duty without forced ventilation) and efficiency curves

Torque from 305 to 715 N.m

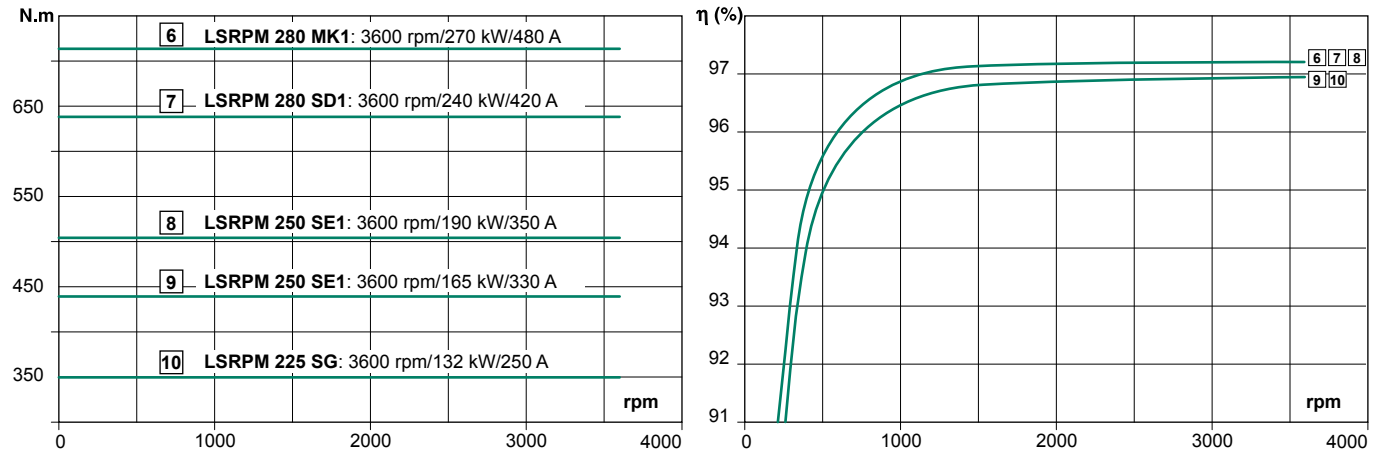

Torque from 715 to 1500 N.m

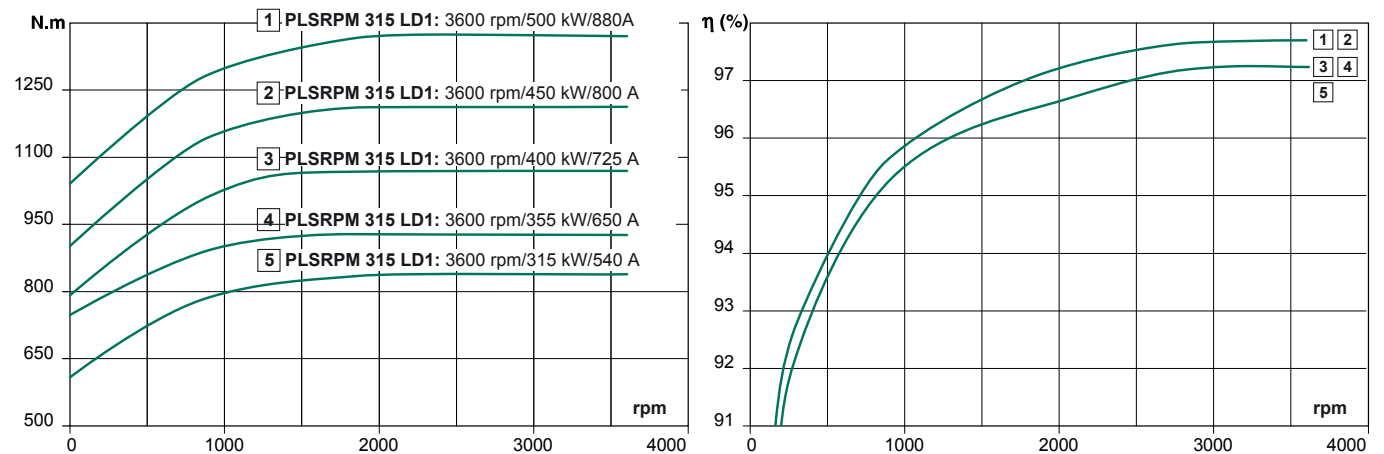

Thermal torque (S1 duty without forced ventilation) and efficiency curves

Torque from 0 to 110 N.m

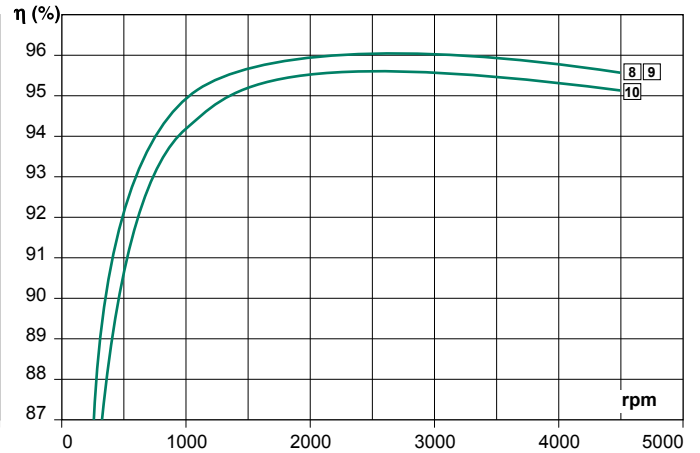
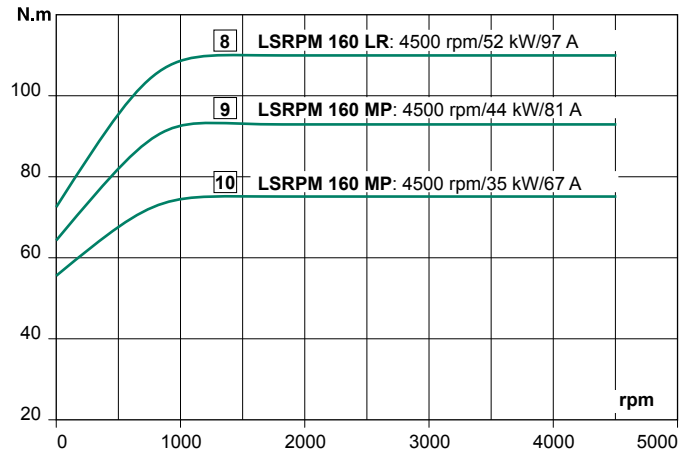

Torque from 110 to 360 N.m

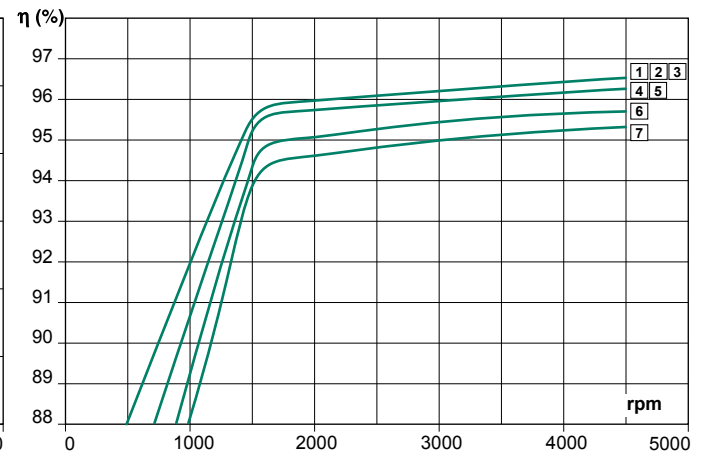
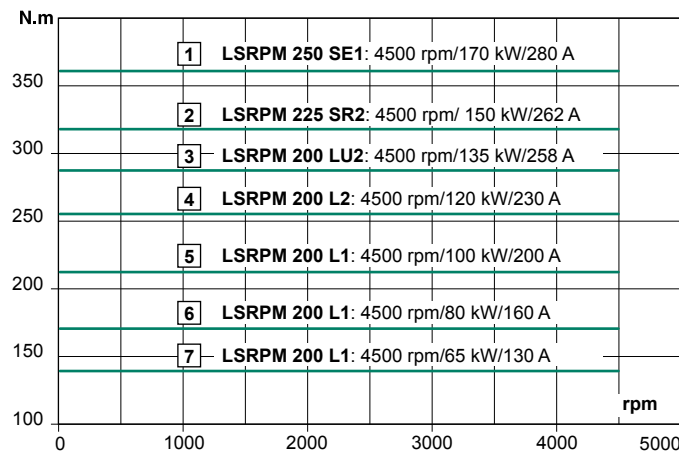

Thermal torque (S1 duty without forced ventilation) and efficiency curves

Torque from 0 to 90 N.m

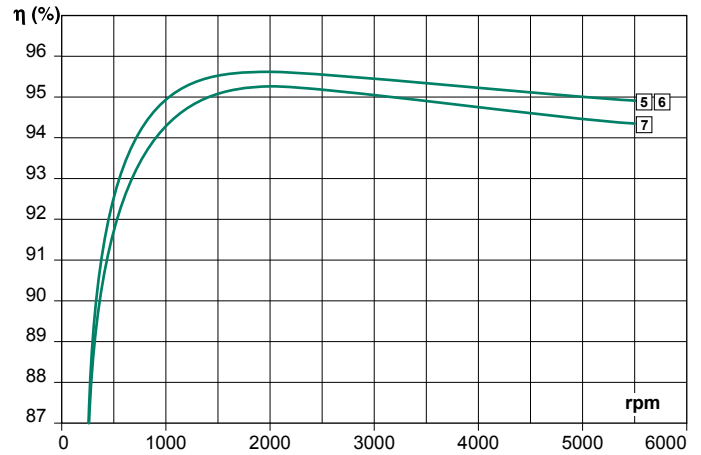
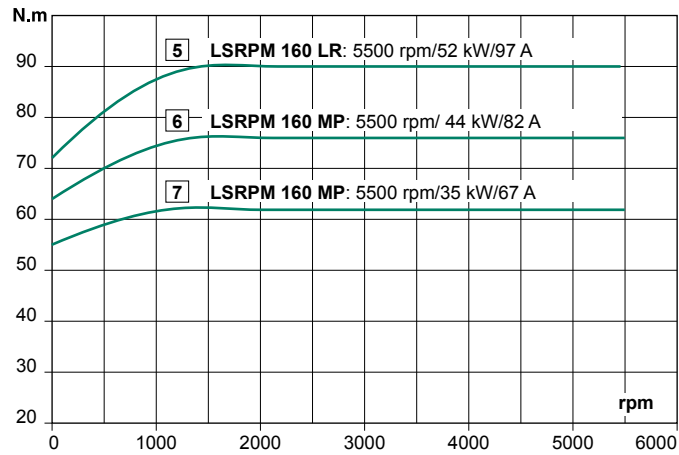

Torque from 90 to 240 N.m

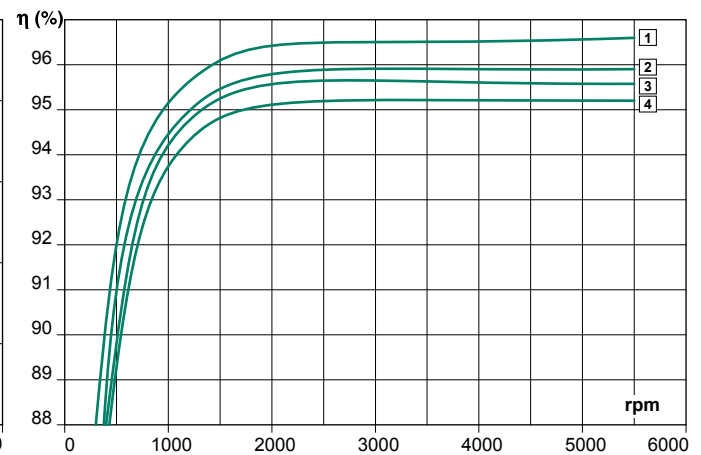
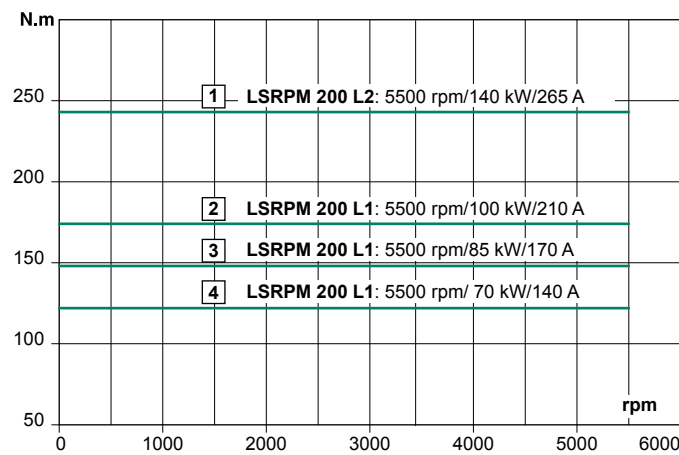

Dimensions and weight

Powerdrive FX (to be integrated in the cabinet)

Ratings	H (mm)	W (mm)	D (mm)	Weight (kg)
33 to 50T	587	256	233	52
60 to 100T	788	256	281	56



Powerdrive MD2MS (wall-mounting version)

Ratings	H (mm)	W (mm)	D (mm)	Weight (kg)
60 to 100T	1383	490	654	140
120T and 150T	1383	490	654	190
180T	1883	490	654	200
220T and 270T	1883	490	654	240

The following options can be added to Powerdrive MD2MS without altering its size: RFI filter, switch, IP54 version, heating kit, emergency stop, communication modules, additional I/O and speed feedback modules.



Powerdrive MD2S (free-standing cubicle)

The cabinet-mounted solution is obtained by assembling cabinet modules 400 or 600 mm wide and 600 mm deep.

• The table below indicates the width (W in mm) of the product depending on the integrated options:

MD2S ratings	W/o options		With option				Width W (mm)
	Width W (mm)	Braking transistor	RFI filter	High-speed fuses	Switch		
100T to 150T	406	✓	✓	✓	✓	406	
180T to 270T	406	✓	✓	✓	✓	606	
340T & 400 T	606	✓	✓	✓	✓	1006	
470T & 570 T	606	✓	✓	✓	✓	1006	
600 T and 750 T	1206	✓	✓	✓	✓	1806	

The following options can be integrated in Powerdrive MD2S without altering its size: emergency stop, communication modules, additional I/O modules, speed feedback modules.

• The table below indicates the height (H) of the product depending on the integrated options:

Protection		Baseplate options		Height (H) mm
IP21	IP54	100 mm	200 mm	
✓				2160
✓		✓		2260
✓			✓	2360
	✓			2260
	✓	✓		2360
	✓		✓	2460

For more precise information depending on the options, use the Configurator: <http://configuratorls.leroy-somer.com>

• The values indicated in the table below are maximum net weights.

MD2 ratings	Weight without option (kg)	Weight maximum (kg)
100T to 150T	225	260
180T to 270T	260	360
340T and 400T	380	560
470T and 570T	410	610
600T and 750T	760	1100

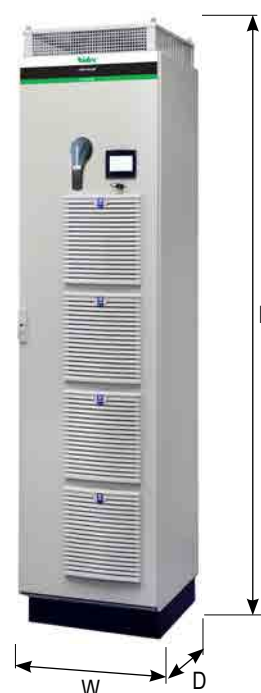

Motor dimensions

Shaft extensions

Dimensions in millimetres

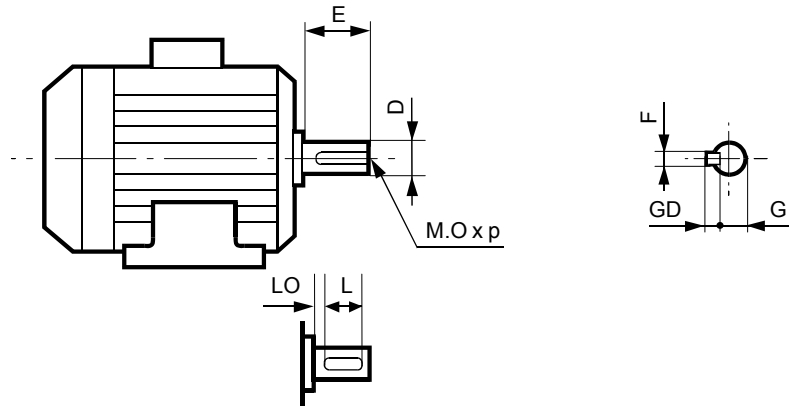

Type	Main shaft extensions																	
	Range 1500 and 1800									2400 to 5500 range								
	F	GD	D	G	E	O	p	L	LO	F	GD	D	G	E	O	p	L	LO
LSRPM 160 MP/LR	14	9	48k6	42.5	110	16	36	98	6	14	9	48k6	42.5	110	16	36	98	6
LSRPM 200 L/L1/L2/LU/LU2	16	10	55m6	49	110	20	42	97	13	16	10	55m6	49	110	20	42	97	13
LSRPM 225 ST1/ST2/SR2/SG/MR1	18	11	60m6	53	140	20	42	126	14	18	11	60m6	53	140	20	42	126	14
LSRPM 250 SE/SE1/ME/ME1/MY	18	11	65m6	58	140	20	42	126	14	18	11	65m6	58	140	20	42	126	14
LSRPM 280 SC/SD/SD1	20	12	70m6	62.5	140	20	42	125	15	20	12	70m6	62.5	140	20	42	125	15
LSRPM 280 MK1/SCM	20	12	75m6	67.5	140	20	42	125	15	20	12	75m6	67.5	140	20	42	125	15
LSRPM 315 SP1/SN	22	14	80m6	71	170	20	42	155	15	22	14	80m6	71	170	20	42	155	15
LSRPM 315 MR1/MP1/SR1	22	14	85m6	76	170	20	42	155	15	22	14	85m6	76	170	20	42	155	15
PLSRPM 315 LD1	22	14	95m6	85	170	16	36	152	15	22	14	80m6*	71	170	20	42	155	15

* 85m6 from 400 kW for the 3000 and 3600 ranges

Motor dimensions

Foot mounted IM B3 (IM 1001)

Dimensions in millimetres

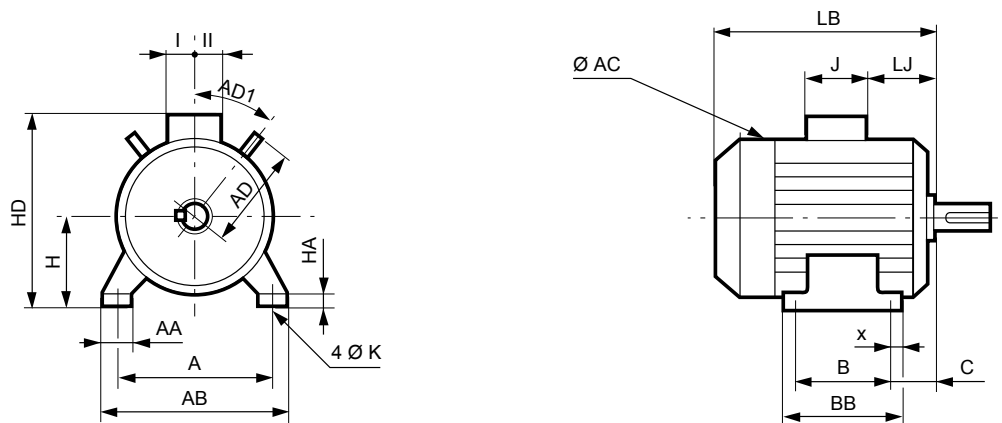

Type	Main dimensions																		
	A	AB	B	BB	C	X	AA	K	HA	H	AC	HD	LB	LJ	J	I	II	AD	AD1
LSRPM 160 MP	254	294	254	298	108	22	64	14	25	160	310	391	555	53	186	112	95	155	45
LSRPM 160 LR	254	294	254	298	108	22	64	14	25	160	310	391	571	53	186	112	95	155	45
LSRPM 200 L	318	388	305	375	133	35	103	18,5	36	200	390	476	621	77	186	112	98	-	-
LSRPM 200 L1	318	388	305	375	133	35	103	18,5	36	200	390	510	621	55	231	119	141	-	-
LSRPM 200 L2	318	388	305	375	133	35	103	18,5	36	200	390	564	621	59	292	151	181	-	-
LSRPM 200 LU	318	388	305	375	133	35	103	18,5	36	200	390	476	669	77	186	112	98	-	-
LSRPM 200 LU2	318	388	305	375	133	35	103	18,5	36	200	390	564	669	59	292	151	181	-	-
LSRPM 225 ST1	356	431	286	386	149	50	127	18,5	36	225	390	535	627	61	231	119	141	-	-
LSRPM 225 ST2	356	431	286	386	149	50	127	18,5	36	225	390	589	627	66	292	151	181	-	-
LSRPM 225 SR2	356	431	286	386	149	50	127	18,5	36	225	390	589	676	66	292	151	181	-	-
LSRPM 225 MR1	356	431	311	386	149	50	127	18,5	36	225	390	535	676	68	231	119	141	-	-
LSRPM 225 SG	356	420	286	375	149	30	65	18,5	33	225	479	630	810	68	292	151	181	-	-
LSRPM 250 MY	406	470	349	449	168	70	150	24	47	250	390	560	627	61	231	119	141	-	-
LSRPM 250 SE	406	470	311	420	168	35	90	24	36	250	479	655	810	68	292	151	181	-	-
LSRPM 250 SE1	406	470	311	420	168	35	90	24	36	250	479	744	810	4	420	180	235	-	-
LSRPM 250 ME	406	470	349	420	168	35	90	24	36	250	479	655	810	68	292	151	181	-	-
LSRPM 250 ME1	406	470	349	420	168	35	90	24	36	250	479	744	810	4	420	180	235	-	-
LSRPM 280 SC	457	520	368	478	190	35	90	24	35	280	479	685	810	68	292	148	180	-	-
LSRPM 280 SCM	457	520	368	478	190	35	90	24	35	280	479	685	810	68	292	151	181	-	-
LSRPM 280 SD	457	520	368	478	190	35	90	24	35	280	479	685	870	68	292	148	180	-	-
LSRPM 280 SD1	457	520	368	478	190	35	90	24	35	280	479	774	870	4	420	180	235	-	-
LSRPM 280 MK1	457	533	419	495	190	40	85	24	35	280	586	835	921	35	420	180	235	-	-
LSRPM 315 SN	508	594	406	537	216	40	140	28	50	315	479	720	870	68	292	151	181	-	-
LSRPM 315 SP1	508	594	406	537	216	40	114	28	70	315	586	870	947	61	420	180	235	-	-
LSRPM 315 SR1	508	594	406	537	216	40	114	28	70	315	586	870	1017	62	420	180	235	-	-
LSRPM 315 MP1	508	594	457	537	216	40	114	28	70	315	586	870	947	61	420	180	235	-	-
LSRPM 315 MR1	508	594	457	537	216	40	114	28	70	315	586	870	1017	61	420	180	235	-	-
PLSRPM 315 LD1	508	608	508	588	216	40	100	28	26	315	680	865	1084	241	418	183	219	-	-
PLSRPM 315 LD1 with feed	508	608	508	588	216	40	100	28	26	315	680	865	1084	241	418	179	402*	-	-

* 393 with straight feed; 402 with slanted feed

For additional information on the terminal boxes with feed for PLSRPM motors, refer to the "Terminal boxes and connection" section.

Dimensions in millimetres

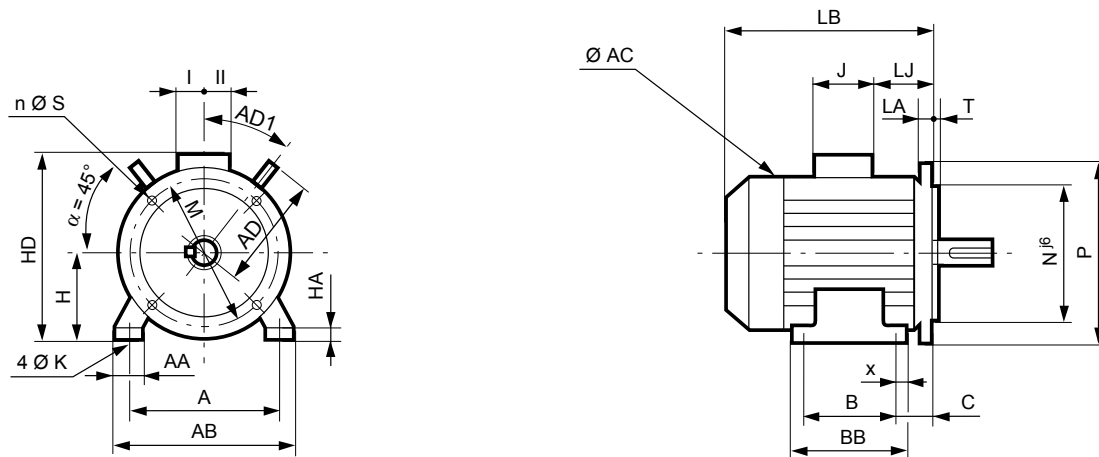

Type	Main dimensions																			
	A	AB	B	BB	C	X	AA	K	HA	H	AC	HD	LB	LJ	J	I	II	AD	AD1	Sym.
LSRPM 160 MP	254	294	254	298	108	22	64	14	25	160	310	391	555	53	186	112	95	155	45	FF300
LSRPM 160 LR	254	294	254	298	108	22	64	14	25	160	310	391	571	53	186	112	95	155	45	FF300
LSRPM 200 L	318	388	305	375	133	35	103	18,5	36	200	390	476	621	77	186	112	98	-	-	FF350
LSRPM 200 L1	318	388	305	375	133	35	103	18,5	36	200	390	510	621	55	231	119	141	-	-	FF350
LSRPM 200 L2	318	388	305	375	133	35	103	18,5	36	200	390	571	621	59	292	148	180	-	-	FF350
LSRPM 200 LU	318	388	305	375	133	35	103	18,5	36	200	390	476	669	77	186	112	98	-	-	FF350
LSRPM 200 LU2	318	388	305	375	133	35	103	18,5	36	200	390	571	669	59	292	148	180	-	-	FF350
LSRPM 225 ST1	356	431	286	386	149	50	127	18,5	36	225	390	535	627	62	231	119	141	-	-	FF400
LSRPM 225 ST2	356	431	286	386	149	50	127	18,5	36	225	390	596	627	66	292	148	180	-	-	FF400
LSRPM 225 SR2	356	431	286	386	149	50	127	18,5	36	225	390	596	676	66	292	148	180	-	-	FF400
LSRPM 225 MR1	356	431	311	386	149	50	127	18,5	36	225	390	535	676	68	231	119	141	-	-	FF400
LSRPM 225 SG	356	420	286	375	149	50	65	18,5	30	225	479	629	810	68	292	148	180	-	-	FF400
LSRPM 250 MY	406	470	349	449	168	70	150	24	47	250	390	560	628	61	231	119	142	-	-	FF500
LSRPM 250 SE	406	470	311	420	168	35	90	24	36	250	479	655	810	68	292	148	180	-	-	FF500
LSRPM 250 SE1	406	470	311	420	168	35	90	24	36	250	479	744	810	4	420	180	235	-	-	FF500
LSRPM 250 ME	406	470	349	420	168	35	90	24	36	250	479	655	810	68	292	148	180	-	-	FF500
LSRPM 250 ME1	406	470	349	420	168	35	90	24	36	250	479	744	810	4	420	180	235	-	-	FF500
LSRPM 280 SC	457	520	368	478	190	35	90	24	35	280	479	685	810	68	292	148	180	-	-	FF500
LSRPM 280 SCM	457	520	368	478	190	35	90	24	35	280	479	686	810	68	292	151	181	-	-	FF500
LSRPM 280 SD	457	520	368	478	190	35	90	24	35	280	479	685	870	68	292	148	180	-	-	FF500
LSRPM 280 SD1	457	520	368	478	190	35	90	24	35	280	479	774	870	4	420	180	235	-	-	FF500
LSRPM 280 MK1	457	520	419	495	190	40	85	24	35	280	586	834	921	35	420	180	235	-	-	FF500
LSRPM 315 SN	508	594	406	537	216	40	140	28	50	315	479	721	870	68	292	151	181	-	-	FF600
LSRPM 315 SP1	508	594	406	537	216	40	114	28	70	315	586	870	947	61	420	180	235	-	-	FF600
LSRPM 315 SR1	508	594	406	537	216	40	114	28	70	315	586	867	1017	62	418	180	235	-	-	FF600
LSRPM 315 MP1	508	594	457	537	216	40	114	28	70	315	586	867	947	62	418	180	235	-	-	FF600
LSRPM 315 MR1	508	594	457	537	216	40	114	28	70	315	586	870	1017	61	420	180	235	-	-	FF600
PLSRPM 315 LD1 ⁽¹⁾	508	608	508	588	216	40	100	28	26	315	680	865	1085	241	418	183	219	-	-	FF740
PLSRPM 315 LD1 with feed	508	608	508	588	216	40	100	28	26	315	680	865	1084	241	418	179	402*	-	-	-

⁽¹⁾ from:

- 315 kW for the 1500 and 1800 ranges,
- 400 kW for the 3000 and 3600 ranges,

the PLSRPM315LD1 in IMB35 configuration must run with radial forced ventilation.

* 393 with straight feed; 402 with slanted feed

Motor dimensions

Flange mounted IM B5 (IM 3001)* IM V1 (IM 3011)

Dimensions in millimetres

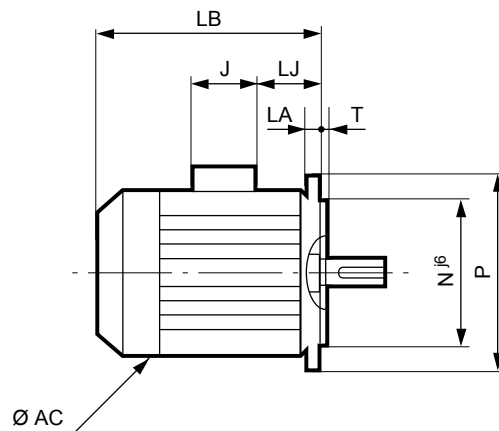
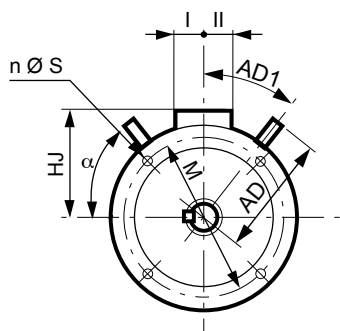

Type	Main dimensions								
	AC	LB	HJ	LJ	J	I	II	AD	AD1
LSRPM 160 MP	264	555	231	53	186	112	95	155	45
LSRPM 160 LR	264	571	231	53	186	112	95	155	45
LSRPM 200 L	390	621	276	77	186	112	98	-	-
LSRPM 200 L1	390	621	310	55	231	119	141	-	-
LSRPM 200 L2	390	621	364	59	292	148	180	-	-
LSRPM 200 LU	390	669	276	77	186	112	98	-	-
LSRPM 200 LU2	390	669	364	59	292	148	180	-	-
LSRPM 225 ST1	390	627	310	61.5	231	119	141	-	-
LSRPM 225 ST2	390	627	364	-	292	148	180	-	-
LSRPM 225 SR2	390	676	364	-	292	148	180	-	-
LSRPM 225 MR1	390	535	276	61.5	231	119	141	-	-
LSRPM 225 SG	479	810	405	68	292	148	180	-	-
LSRPM 250 MY	390	627.5	310	61	231	119	142	-	-
LSRPM 250 SE	479	810	405	68	292	148	180	-	-
LSRPM 250 SE1	479	810	494	4	420	180	235	-	-
LSRPM 250 ME	479	810	405	68	292	148	180	-	-
LSRPM 250 ME1	479	810	494	4	420	180	235	-	-
LSRPM 280 SC	479	810	405	68	292	148	180	-	-
LSRPM 280 SCM	479	810	405	67.5	292	151	181	-	-
LSRPM 280 SD	479	870	405	68	292	148	180	-	-
LSRPM 280 SD1	479	870	494	4	420	180	235	-	-
LSRPM 280 MK1	586	921	555	35	420	180	235	-	-
LSRPM 315 SN	479	870	405	67.5	292	151	181	-	-
LSRPM 315 SP1	586	947	554	61	420	180	235	-	-
LSRPM 315 SR1	586	1017	555	61.5	418	180	235	-	-
LSRPM 315 MP1	586	947	555	61.5	418	180	235	-	-
LSRPM 315 MR1	586	1017	555	61	420	180	235	-	-

Symbol IEC	Flange dimensions							
	M	N	P	T	n	α	S	LA
FF300	300	250	350	5	4	45	18.5	14
FF300	300	250	350	5	4	45	18.5	14
FF350	350	300	400	5	4	45	18.5	15
FF350	350	300	400	5	4	45	18.5	15
FF350	350	300	400	5	4	45	18.5	15
FF350	350	300	400	5	4	45	18.5	15
FF400	400	350	450	5	8	22.5	18.5	16
FF400	400	350	450	5	8	22.5	18.5	15
FF400	400	350	450	5	8	22.5	18.5	15
FF400	400	350	450	5	8	22.5	18.5	16
FF400	400	350	450	5	8	22.5	18.5	16
FF500	500	450	550	5	8	22.5	18.5	18
FF500	500	450	550	5	8	22.5	18.5	22
FF500	500	450	550	5	8	22.5	18.5	22
FF500	500	450	550	5	8	22.5	18.5	22
FF500	500	450	550	5	8	22.5	18.5	22
FF500	500	450	550	5	8	22.5	18.5	22
FF500	500	450	550	5	8	22.5	18.5	22
FF500	500	450	550	5	8	22.5	18.5	22
FF500	500	450	550	5	8	22.5	18.5	22
FF500	500	450	550	5	8	22.5	18.5	22
FF600	600	550	660	6	8	22.5	24	22
FF600	600	550	660	6	8	22.5	24	22
FF600	600	550	660	6	8	22.5	24	22
FF600	600	550	660	6	8	22.5	24	22
FF600	600	550	660	6	8	22.5	24	22
FF600	600	550	660	6	8	22.5	24	22
FF740	740	680	800	6	8	22.5	24	25

* for axis height > 250 mm in IM 3001 use, please call

Dimensions of shaft extensions identical to those for foot mounted motors.

Dimensions in millimetres

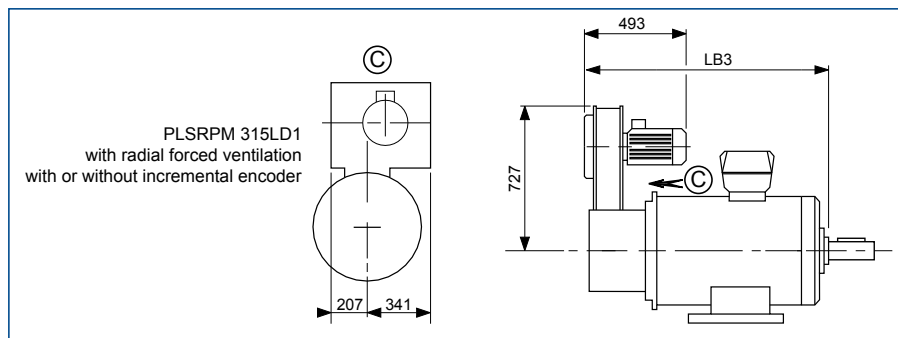
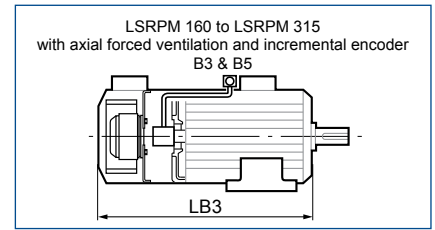
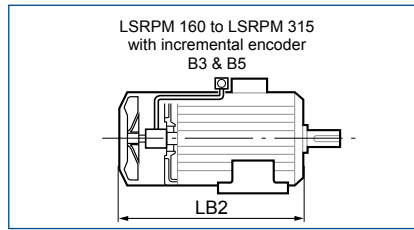
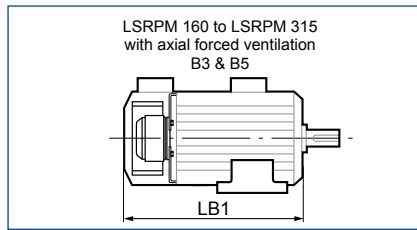

Type	LB1	LB2	LB3
LSRPM 160 MP	709	555	709
LSRPM 160 LR	704	576	709
LSRPM 200 L/L1/L2	802	674	802
LSRPM 200 LU/LU2	847	723	847
LSRPM 225 ST1/ST2	808	680	808
LSRPM 225 SR2	854	730	854
LSRPM 225 MR1	854	730	854
LSRPM 225 SG	1012	860	1012
LSRPM 250 MY	808	680	808
LSRPM 250 SE/SE1	1012	860	1012
LSRPM 250 ME/ME1	1012	860	1012
LSRPM 280 SC/SCM	1012	860	1012
LSRPM 280 SD/SD1	1072	920	1072
LSRPM 280 MK1	1111	965	1111
LSRPM 315 SP1/MP1	1181	991	1181
LSRPM 315 SN	1072	920	1072
LSRPM 315 MR1/SR1	1251	1061	1251
PLSRPM315LD1 with or without feed	-	1164	1317

NB: Dimensions of motors with single-turn and multi-turn absolute encoders will be supplied on request.

Drip cover for operation in vertical position, shaft end facing down

Motor type	LB'	Ø
LSRPM 160 MP/LR	LB + 30	236
LSRPM 200 L/L1/L2/LU/LU2	LB + 36.5	350
LSRPM 225 ST1/ST2/MR1/SR2	LB + 36.5	350
LSRPM 225 SG	LB + 55	350
LSRPM 250 MY	LB + 36.5	350
LSRPM 250 SE/SE1	LB + 55	350
LSRPM 280 SCM/SC/SD/SD1	LB + 55	350
LSRPM 280 MK1	LB + 76.5	505
LSRPM 315 SN	LB + 55	350
LSRPM 315 SP1/MP1/MR1/SR1	LB + 76.5	505

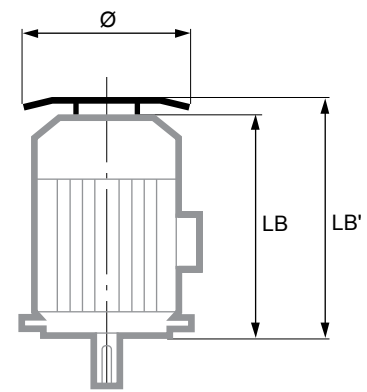

Influence of the AC supply

Each industrial power supply has its own intrinsic characteristics (short-circuit capability, voltage value and fluctuation, phase imbalance, etc.) and supplies equipment some of which can distort its voltage either permanently or temporarily (notches, voltage dips, overvoltage, etc.). The quality of the AC supply has an impact on the performance and reliability of electronic equipment, especially variable speed drives.

Nidec drives are designed to operate with the AC supplies typically found on industrial sites throughout the world. However, for each installation, it is important to know the characteristics of the AC supply so that you can take corrective steps in the event of abnormal conditions.

Transient overvoltages

There are numerous sources of overvoltages on an electrical installation:

- Connection/disconnection of banks of power factor correction capacitors
- High-power thyristor-controlled equipment (oven, DC drive, etc.)
- Overhead power supply

Connection/disconnection of a bank of correction capacitors $\cos \varphi$

Connecting power factor correction capacitors in parallel on the drive power supply line when the drive is running can generate transient overvoltages that are likely to trip the drive safety devices, or even damage it in extreme cases.

If banks of power factor correction capacitors are used on the power supply line, make sure that:

- The threshold between steps is low enough to avoid causing overvoltage on the line
- The capacitors are not permanently connected

Presence of commutation notches on the line

When high-power thyristor-controlled equipment is connected on the same line as the drive, it is essential to ensure that the harmonics generated by the commutation notches do not excessively distort the AC voltage and do not create voltage peaks with amplitude higher than $1.6 \times \text{line } V_{\text{rms}}$. If this is the case, it is essential to take corrective measures to guarantee the line supply quality.

Unbalanced power supply

In the same way as can be seen on an electric motor, the line voltage imbalance of a drive can have consequences on its operation. Please refer to the drive installation manual.

Equipotential bonding

The equipotential earth bonding of some industrial sites is sometimes neglected. This lack of equipotentiality leads to leakage currents which flow via the earth cables (green/yellow), the machine chassis, the pipework, etc., and also via the electrical equipment. In some extreme cases, these currents can trip the drive.

It is essential that the earth network is designed and implemented by the installation supervisor so that its impedance is as low as possible, so as to distribute the fault currents and high-frequency currents without them passing through electrical equipment.

Metal grounds must be mechanically connected to each other with the largest possible electrical contact area. Under no circumstances can earth connections designed to protect people, by linking metal grounds to earth via a cable, serve as a substitute for ground connections (see IEC 61000-5-2).

The immunity and radio-frequency emission level are directly linked to the quality of the ground connections.

Connection of control and encoder cables

CAUTION: Strip back the shielding on the metal clamp collars in order to ensure 360° contact.

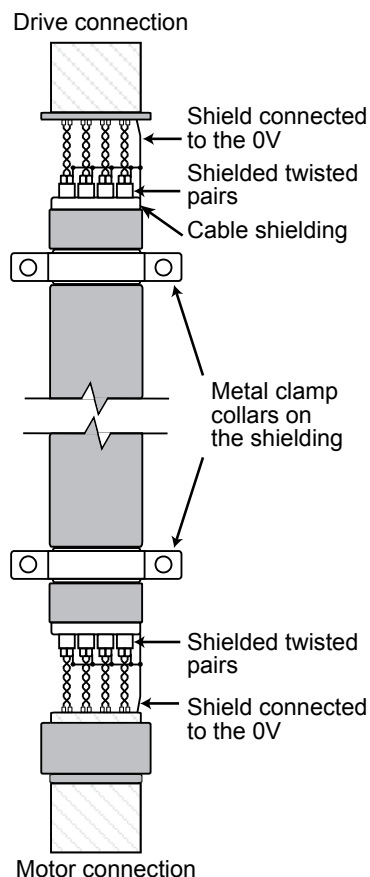

Power cables

The following information is given for guidance only, and should never be used as a substitute for the current standards, nor does it relieve the installation company of their responsibility. For more information, please refer to technical specification IEC 60034-25.

To ensure the safety of personnel, the size of the earthing cables should be determined individually in accordance with local regulations.

For compliance with standard EN 61800-3, the power conductors between drive and motor must be shielded. Use a special variable speed cable: shielded with low stray capacity and with 3 protective earth (PE) conductors arranged at 120° (diagram below). There is no need to shield the drive power supply cables.

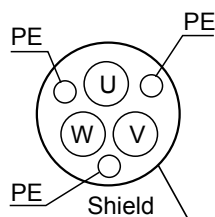

CAUTION! The configuration below is acceptable only if the motor cables incorporate phase conductors with a cross-section below 10 mm² (motors < 30 kW / 40 HP).

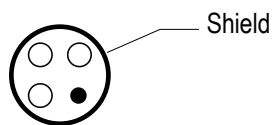

The use of armoured unipolar cables is forbidden.

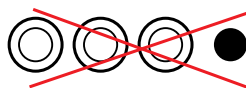

The motor-drive unit wiring must be symmetrical (U,V,W at the motor end must correspond to U,V,W at the drive end) with the cable shielding earthed at both the drive end and motor end over 360°.

When the installation complies with emissions standard EMC 61800-3 category C2 (if an HV/LV transformer belongs to the user), the shielded motor power supply cable can be replaced with a 3-core + earth cable placed in a fully-enclosed metal conduit (metal cable duct for example). This metal conduit must be mechanically connected to the electrical cabinet and the structure supporting the motor.

If the conduit consists of several pieces, these should be interconnected by braids to ensure earth continuity.

The cables must be fixed securely at the bottom of the conduit.

The motor earth terminal (PE) must be connected directly to the drive earth terminal.

A separate protective earth (PE) conductor is mandatory if the conductivity of the cable shielding is less than 50% of the conductivity of the phase conductor.

Typical variable speed drive installation

The following information is given for guidance only, and should never be used as a substitute for the current standards, nor does it relieve the installation company of their responsibility.

Depending on the installation, more optional elements can be added:

Switch-fuse : a padlockable breaking device must be installed to isolate the installation should operator intervention be necessary. This device must provide protection against overheating and short-circuits. The fuse rating is stated in the drive documentation. The switch-fuse can be replaced with a circuit-breaker (with appropriate breaking capacity).

RFI filter : its role is to reduce the drive electromagnetic emissions, and thus comply with EMC standards. Leroy-Somer drives are, as standard, equipped with an internal RFI filter. Some environments require the addition of an external filter. Please consult the drive documentation to find out the drive conformance levels, with and without an external RFI filter.

Drive power supply cables : these cables do not necessarily need shielding. Their cross-section is recommended in the drive documentation, however, it can be adapted according to the type of cable, installation method, the cable length (voltage drop), etc. See below “Sizing the power cables”.

Line reactor: its role is to reduce the risk of damage to the drives following phase imbalance or significant disturbance on the electrical mains supply. The line reactor can also reduce low-frequency harmonics. It is integrated as standard in the Powerdrive MD2.

Motor power supply cables: these cables must be shielded to ensure EMC conformance of the installation. The cable shielding must be connected over 360° at both ends. At the motor end, special EMC cable glands are available as an option. The cable cross-section is recommended in the drive documentation, however, it can be adapted according to the type of cable, installation method, the cable length (voltage drop), etc. See below “Sizing the power cables”.

Encoder cables: the sensor cable shielding is important due to interference with the power cables. This cable must be laid at least 30 cm away from any power cables. See “Encoders” section.

Sizing the power cables: the drive and motor power supply cables must be sized according to the applicable standard, and according to the design current, stated in the drive documentation.

The different factors to be taken into account are:

- The installation method: in a conduit, a cable tray, suspended, etc.
- The type of conductor: copper or aluminium

Once the cable cross-section has been determined, check the voltage drop at the motor terminals. A significant voltage drop results in increased current and additional losses in the motor (temperature rise).

Equipotential bonding between the frame, motor, drive, transformer and ground carried out in accordance with good practice will contribute significantly to reducing the voltage on the shaft and the motor casing, resulting in fewer high-frequency leakage currents. Premature breakage of bearings and auxiliary equipment, such as encoders, should also be avoided wherever possible.

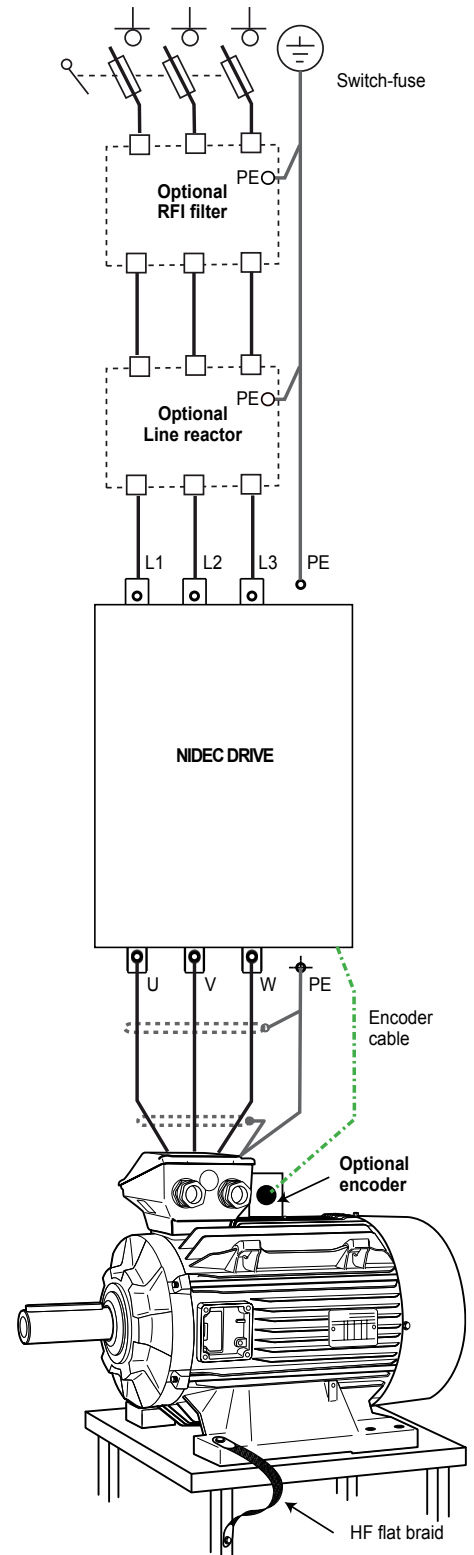

Selection of position sensor

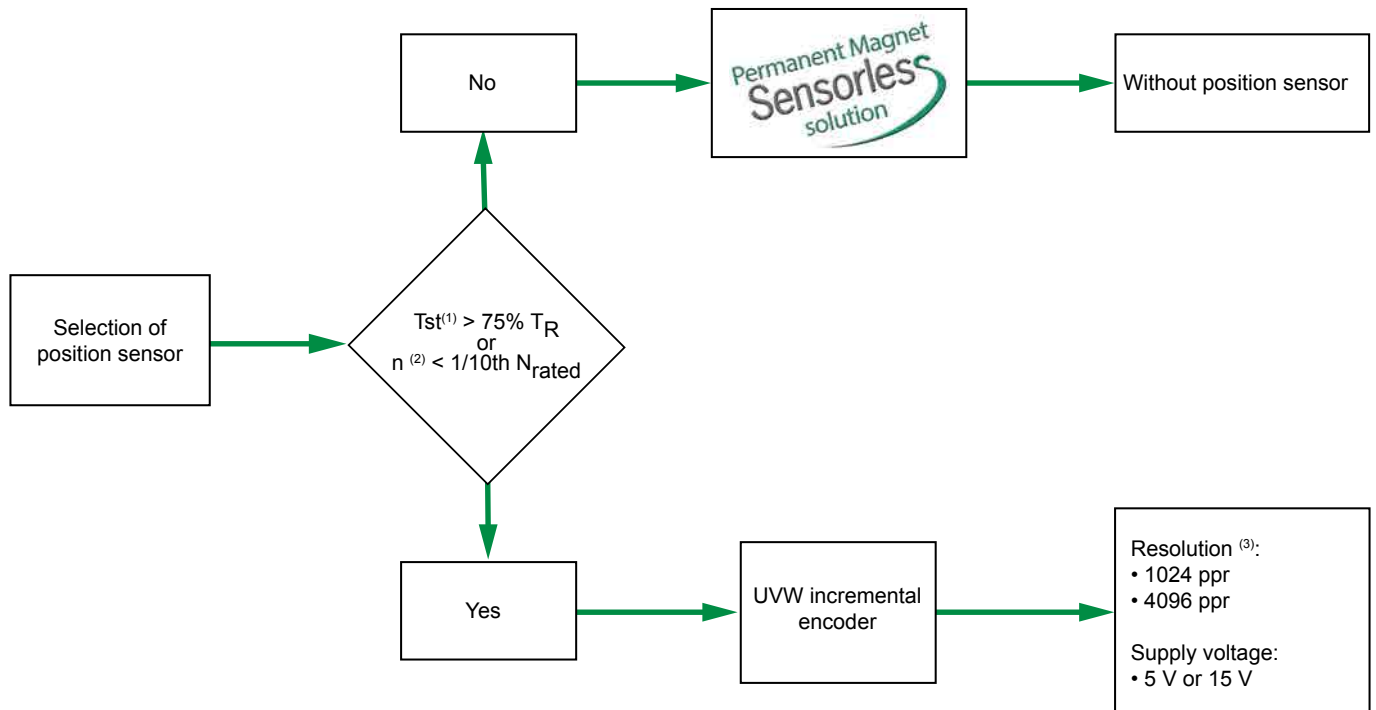

(1) between 0 and 10% of rated speed

(2) minimum speed

(4) caution, if the speed is greater than or equal to 3000 rpm, the resolution must not exceed 1024 ppr.

SENSORLESS mode

Drives in the Powerdrive range enable operation in sensorless mode (without encoder) in the majority of applications. In this operating mode, the rotor position feedback is calculated using the electrical measurements taken by the drive (software sensor).

When operating permanent magnet synchronous machines in Sensorless mode, ensure that the points below are adhered to:

- Torque limited to 75% of T_{rated} , between 0 and 10% of rated speed
- Machine speed > 1/10th of rated speed



Incremental encoder with commutation channels

This pulse generator supplies a number of pulses on channels A,A/, B,B/, 0 marker, 0/ marker proportional to the speed. The information on commutation channels UVW enables the position of the rotor to be known to within about 60° (electrical degrees).

A 1024 ppr encoder is sufficient for most applications. However, where stability at very low speed (<10 rpm) is required, use of a higher-resolution encoder is recommended.

For motors with frame sizes 200 and above, the encoder is galvanically isolated as standard in relation to the motor shaft.

Powerdrive can supply encoders with +5 V DC or +15 V DC.

(*) : The KHK5S encoder is a strengthened encoder, recommended for machines located in severe environments (dusty atmospheres).

Encoder-drive connecting cable

It may be possible to order a suitable cable, guaranteeing optimum performance of the drive connection. Please consult your usual contact.

UVW incremental encoders		
Encoder reference	KHO5	KHK5S*
Supply voltage	5/30 VDC	5/30 VDC
Positions per revolution	1024 or 4096	1024 or 4096
Output stage	TTL (RS422)	TTL (RS422)
Max. current (no load)	140 mA	140 mA
Mechanical speed max in continuous operation	6000 rpm	6000 rpm
Shaft diameter	14 mm (1)	14 mm (1)
Protection	IP65	IP67
Operating temperature	-30° +80°C	-30° +80°C
Certification	CE	CE
Motor end finish	M23 17 pins	M23 17 pins
Drive end finish	HD15	HD15

— : standard encoder type
(1) through hollow shaft, closed



Motors fitted with insulated bearings are specified on page 49

Standard motors are compatible with power supplies with the following characteristics:

- U rms = 480 V max.
- Value of voltage peaks generated at the terminals: 1500 V max.

However, they can be supplied with power in more severe conditions if additional protection is provided.

Reinforced winding insulation

The main effect connected with supplying power via an electronic drive is overheating of the motor due to the non-sinusoidal shape of the signal. In addition, this can result in accelerated ageing of the winding through the voltage peaks generated at each pulse in the power supply signal (see Figure 1).

For peak values greater than 1500 V, a super-insulation option for the winding is available over the entire range.

Reinforced insulation of the mechanism

Supplying power via a drive can affect the mechanism and lead to premature wear of the bearings.

This is because, in any motor, a shaft voltage exists with respect to earth.

This voltage, due to electro-mechanical dissymmetries, creates a potential difference between the rotor and the stator. This effect can generate

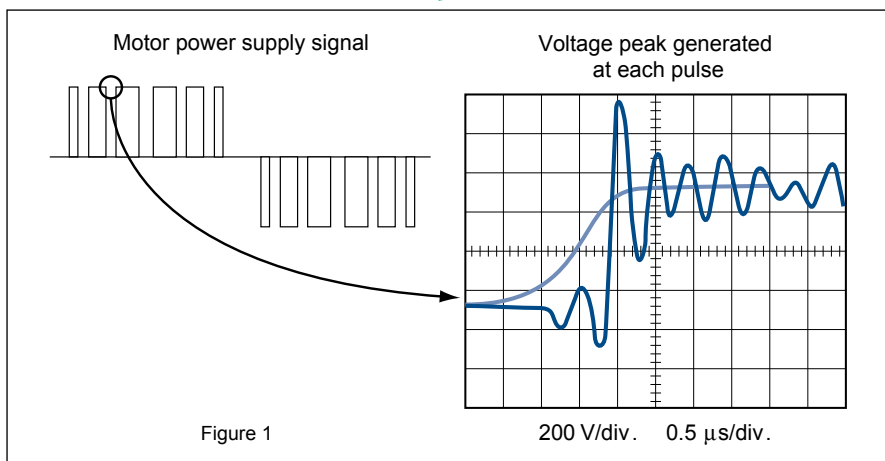

electrical discharges between balls and slip-rings and lead to a reduction in bearing life.

If power is supplied via a PWM drive, a second effect is added: high-frequency currents generated by the IGBT output bridges of the drives. These currents “attempt” to spread towards the drive and therefore flow through the stator and via earth where the link between the casing, machine frame and earth is correctly made.

Otherwise, it will flow via the least resistive path: end shields/bearings/shaft/machine coupled to the motor. In these situations, therefore, protection for the bearings must be provided.

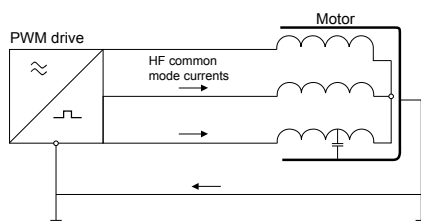

For this reason, an “insulated bearing” option is available over the entire range from frame size 200.

Insulated bearing characteristics

The outer races of the bearings are coated with a layer of electrically insulating ceramic.

The dimensions and tolerances of these bearings are identical to the standard ones used and can therefore be fitted instead, with no modifications to the motors. The breakdown voltage is 500 V.

To find out which type of bearings are fitted as standard, see the “Bearings and lubrication” section.

Summary of recommended protection devices

Line voltage	Cable length	Frame size	Winding protection
≤ 480 V	≤ 20 m	All frame sizes	Standard*
	> 20 m and < 100 m	< 315	Standard*
> 480 V and ≤ 690 V	≤ 20 m	≥ 315	RIS or drive filter**
		< 250	Standard*
	> 20 m and < 100 m	< 250	RIS or drive filter**
		≥ 250	RIS or drive filter**

* Standard insulation = 1500 V peak and 3500 V/μs.

** RIS: Reinforced insulation system. Do not use a drive filter in Sensorless mode.

Forced ventilation

To keep the rated torque over the entire speed range, forced ventilation may be necessary. Refer to the thermal torque curves of the motors in the "Performance" section

The motors are self-cooled as standard*

Characteristics of forced ventilation units

(please consult your usual contact for motors ≥ 225 SG in the speed ranges ≥ 2400 rpm)

Motor type	Supply voltage ¹ FV	FV consumption		Ingress protection ² FV	Type of mounting
		P(W)	I (A)		
LSRPM 160	three-phase 230/400 V 50 Hz 265/460 V 60 Hz	48 57	0.25/0.14 0.22/0.13	IP 55	axial
LSRPM 250 MY LSRPM 200 to 225 except LSRPM 225 SG	three-phase 230/400 V 50 Hz 254/460 V 60 Hz	150	0.94/0.55	IP 55	axial
LSRPM 225 SG LSRPM 315 SN LSRPM 250 and 280 except LSRPM 280 MK1 and LSRPM 250 MY	three-phase 230/400 V 50 Hz 254/460 V 60 Hz	200	1.4/0.8	IP 55	axial
LSRPM 280 MK1 LSRPM 315 except LSRPM 315 SN	three-phase 230/400 V 50 Hz 254/460 V 60 Hz	750	3.6/2.1	IP 55	axial
PLSRPM 315 LD1	three-phase 230/400 V 50 Hz 254/460 V 60 Hz	3000	10/5.8	IP 55	radial

1. $\pm 10\%$ for voltage, $\pm 2\%$ for frequency.

2. Ingress protection of the forced ventilation installed on the motor.

* Except for PLSRPM 315LD1 motors in IMB35 configuration, from:

- 315 kW for the 1500 and 1800 ranges

- 400 kW for the 3000 and 3600 ranges

Cable glands

There must be ground continuity between the cable and the motor ground to guarantee protection of the installation in accordance with EMC

directive 2004/108/EC. An optional **cable gland with anchorage on shielded cable** is therefore available over the entire range.

The motors are supplied with pre-drilled and tapped terminal boxes or an undrilled mounting plate for mounting cable glands see page 50

Type and cable size of cable glands

Cable gland type	Cable size	
	Min. cable \varnothing (mm) W	Max. cable \varnothing (mm) A
ISO 16	6	11
ISO 20	7.5	13
ISO 25	12.5	18
ISO 32	17.5	25
ISO 40	24.5	33.5
ISO 50	33	43
ISO 63	42.5	55

The motors are fitted with PTC sensors as standard

Motors are protected by the variable speed drive, placed between the isolating switch and the motor. The drive provides total protection of the motor against overloads.

Dyneo® motors are fitted with PTC sensors in the winding as standard. As an option, specific thermal protection sensors can be selected from the table below.

It must be emphasized that under no circumstances can these sensors be used to carry out direct regulation of the motor operating cycles.

Fitting thermal protection

- PTO or PTF in command circuits.
- CTP, connected to the drive terminal strip or the associated relay, on the command circuits.
- PT100, KTY or thermocouples, with associated scanning device (or to MDX-I/O Lite optional module of the Powerdrive MD2/FX), in control tables of installations for permanent monitoring.

Motor thermal sensors must be connected in order to maintain optimum motor protection.

Alarm and early warning

All protective equipment can be backed up by another type of protection (with different NRTs): the first device will then act as an early warning (light or sound signals given without shutting down the power circuits), and the second device will be the alarm (shutting down the power circuits).

Built-in indirect thermal protection

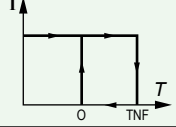
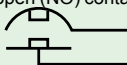
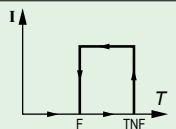
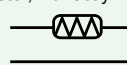
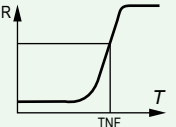
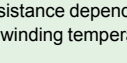
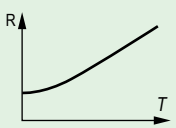
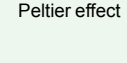
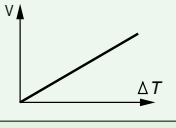
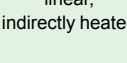
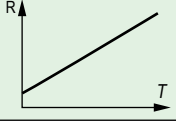
Type	Operating principle	Operating curve	Breaking capacity (A)	Protection provided	Mounting Number of devices*
Normally closed thermal protection PTO	Bimetallic strip, indirectly heated, with normally closed (NC) contact 		2.5 A at 250 V with $\cos \varphi 0.4$	general surveillance for non-transient overloads	Mounted in control circuit 2 or 3 in series
Normally open thermal protection PTF	Bimetallic strip, indirectly heated, with normally open (NO) contact 		2.5 A at 250 V with $\cos \varphi 0.4$	general surveillance for non-transient overloads	Mounted in control circuit 2 or 3 in parallel
Positive temperature coefficient thermistor PTC	Non-linear variable resistor, indirectly heated 		0	general surveillance for transient overloads	Mounted with associated relay in control circuit 3 in series
Temperature sensor KTY	Resistance depends on the winding temperature 		0	High accuracy continuous surveillance of key hot spots	Mounted in control boards with associated reading equipment (or recorder) 1 per hot spot
Thermocouples T ($T < 150^\circ\text{C}$) Copper Constantan K ($T < 1000^\circ\text{C}$) Copper-nickel	Peltier effect 		0	Continuous surveillance of hot spots at regular intervals	Mounted in control boards with associated reading equipment (or recorder) 1 per hot spot
Temperature sensor platinum PT 100	Variable resistor linear, indirectly heated 		0	High accuracy continuous surveillance of key hot spots	Mounted in control boards with associated reading equipment (or recorder) 1 per hot spot

- NRT: nominal running temperature.

- The NRTs are chosen according to the position of the sensor in the motor and the temperature rise class.

- Standard KTY = 84/130

* The number of devices relates to the winding protection.

Motor construction

Definition of “Index of Protection” (IP/IK)

In standard configuration, the motors are IP 55/IK 08 for LSRPM and IP 23/IK 08 for PLSRPM

Ingress protection of electrical equipment enclosures
In accordance with IEC 60034-5 - EN 60034-5 (IP) - IEC 62262 (IK)

1st number: Protection against solid objects			2nd number: Protection against liquids			3rd number: Mechanical protection		
IP	Tests	Definition	IP	Tests	Definition	IK	Tests	Definition
0		No protection	0		No protection	00		No protection
1		Protected against solid objects larger than 50 mm (e.g. accidental contact with the hand)	1		Protected against water drops falling vertically (condensation)	01		Impact energy: 0.15 J
2		Protected against solid objects larger than 12 mm (e.g. a finger)	2		Protected against water drops falling at up to 15° from the vertical	02		Impact energy: 0.20 J
3		Protected against solid objects larger than 2.5 mm (e.g. tools, wires)	3		Protected against rain falling at up to 60° from the vertical	03		Impact energy: 0.37 J
4		Protected against solid objects larger than 1 mm (e.g. thin tools, small wires)	4		Protected against projected water from all directions	04		Impact energy: 0.50 J
5		Protected against dust (no deposits of harmful material)	5		Protected against jets of water from all directions from a hose	05		Impact energy: 0.70 J
6		Protected against any dust penetration	6		Protected against projected water comparable to big waves	06		Impact energy: 1 J
<p>Example:</p> <p>Example of an IP55 machine</p> <p>IP : Ingress protection</p> <p>.5 : Machine protected against dust and accidental contact. Test result: no dust enters in harmful quantities, no risk of direct contact with rotating parts. The test will last for 2 hours.</p> <p>.5 : Machine protected against jets of water from all directions from hoses at 3 m distance with a flow rate of 12.5 l/min at 0.3 bar. The test will last for 3 minutes. Test result: no damage from water projected onto the machine.</p>			7		Protected against the effects of immersion between 0.15 and 1 m	07		Impact energy: 2 J
			8		Protected against prolonged effects of immersion under pressure	08		Impact energy: 5 J
						09		Impact energy: 10 J
						10		Impact energy: 20 J

Motor construction

External finish

Surface protection is defined in standard ISO 12944. This standard defines the expected life of a paint system until the first major application of maintenance paint. Durability is not guaranteed.

Standard EN ISO 12944 is divided into 8 parts. Part 2 discusses the classification of environments.

Leroy-Somer motors are protected with a range of surface finishes.

Surfaces receive appropriate special treatments, as shown below.

Preparation of surfaces

SURFACE	PARTS	TREATMENT
Cast iron	Main bearings	Shot blasting + Primer
Steel	Accessories	Phosphate treatment + Primer
	Terminal boxes - Fan covers	Electrostatic painting or Epoxy powder
Aluminium alloy	Housings - Terminal boxes	Shot blasting

Classification of environments

Leroy-Somer paint systems according to the categories.

ATMOSPHERIC CORROSION CATEGORIES	CORROSION CATEGORY* A/C ISO 12944-2	Durability class	ISO 6270	ISO 9227	LS Form	Leroy-Somer system equivalent
			Water condensation Number of hours	Neutral saline mist Number of hours		
Average	C3	Limited	48	120	100	Ia
		Average	120	240	101b	IIa
		High	240	480	132b	IIb
High	C4	Limited	120	240	-	-
		Average	240	480	102c	IIIa
		High	480	720	106b	IIIb**
Very high (Industry)	C5-I	Limited	240	480	165	IVb**
		Average	480	720	140b	Ve**
		High	720	1440	-	-
Very high (Marine)	C5-M	Limited	240	480	-	-
		Average	480	720	-	-
		High	720	1440	161b	161b**

Standard for LSRPM aluminium and PLSRPM steel motors

* Values given for information only since the substrates vary in nature whereas the standard only takes account of steel substrates.

** Assessment of degree of rusting in accordance with standard ISO 4628 (rust over 1 to 0.5% of the surface).

Standard paint colour reference of LSRPM-PLSRPM motors:

RAL 3005





Motor construction

Mounting arrangements

Mountings and positions (IEC standard 60034-7)

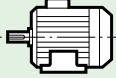
Foot mounted motors

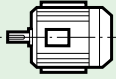
- all frame sizes

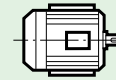
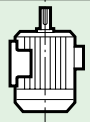
<p>IM 1001 (IM B3)</p> <ul style="list-style-type: none"> - Horizontal shaft - Feet on floor 	<p>IM 1071 (IM B8)</p> <ul style="list-style-type: none"> - Horizontal shaft - Feet on top 
<p>IM 1051 (IM B6)</p> <ul style="list-style-type: none"> - Horizontal shaft - Wall mounted with feet on left when viewed from drive end 	<p>IM 1011 (IM V5)</p> <ul style="list-style-type: none"> - Vertical shaft facing down - Feet on wall 
<p>IM 1061 (IM B7)</p> <ul style="list-style-type: none"> - Horizontal shaft - Wall mounted with feet on right when viewed from drive end 	<p>IM 1031 (IM V6)</p> <ul style="list-style-type: none"> - Vertical shaft facing up - Feet on wall 

(FF) flange mounted motors

- all frame sizes (except IM 3001, which is limited to frame size 225 mm)

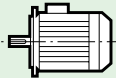
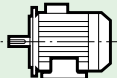
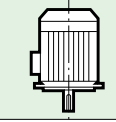
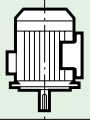
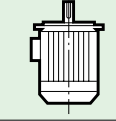
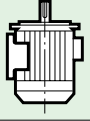
<p>IM 3001 (IM B5)</p> <ul style="list-style-type: none"> - Horizontal shaft 	<p>IM 2001 (IM B35)</p> <ul style="list-style-type: none"> - Horizontal shaft - Feet on floor 
<p>IM 3011 (IM V1)</p> <ul style="list-style-type: none"> - Vertical shaft facing down 	<p>IM 2011 (IM V15)</p> <ul style="list-style-type: none"> - Vertical shaft facing down - Feet on wall 
<p>IM 3031 (IM V3)</p> <ul style="list-style-type: none"> - Vertical shaft facing up 	<p>IM 2031 (IM V36)</p> <ul style="list-style-type: none"> - Vertical shaft facing up - Feet on wall 

Motors without drive end shield

Caution: The protection (IP) specified on the IM B9 and IM B15 motor nameplates is provided by the customer when the motor is assembled.

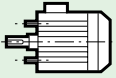
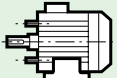
<p>IM 9101 (IM B9)</p> <ul style="list-style-type: none"> - Threaded tie rods - Horizontal shaft 	<p>IM 1201 (IM B15)</p> <ul style="list-style-type: none"> - Foot mounted with threaded tie rods - Horizontal shaft 
--	---

Frame size (mm)	Mounting positions											
	IM 1001	IM 1051	IM 1061	IM 1071	IM 1011	IM 1031	IM 3001	IM 3011	IM 3031	IM 2001	IM 2011	IM 2031
≤ 200	●	●	●	●	●	●	●	●	●	●	●	●
225 and 250	●	●	●	●	●	●	■	●	●	●	●	●
≥ 280	●	■	■	■	■	■	■	●	●	●	●	■

●: possible positions.

■: please consult Leroy-Somer specifying the coupling method and the axial and radial loads if applicable

CAUTION! Particularities linked with the PLSRPM 315LD1 motor

- The IM3001/IM3011 positions are not available
- The IM2001 position requires adding a radial forced ventilation from 315 kW for the 1500 or 1800 ranges, and from 400 kW for the 3000 or 3600 ranges.

Type of grease

When the bearings are not greased for life, the type of grease is indicated on the nameplate.

Avoid mixing greases and adhere to the quantities stated

Permanently greased bearings

Under normal operating conditions, the service life (L10h) of the lubricant is 25,000 hours for a machine installed horizontally and for temperatures less than 25°C.

Bearings fitted as standard

Voltage	Speed (rpm)	Power (kW)	NDE bearing	DE bearing
< 460 V	1500 ≤ N ≤ 2400	< 160	Standard	Standard
		≥ 160	1000 V insulated	
	2400 < N ≤ 3600	< 145	Standard	Standard
		145 ≤ P < 325	1000 V insulated	
	3600 < N ≤ 4500	< 55	Standard	Standard
		≥ 55	1000 V insulated	
	N > 4500	< 55	Standard	Standard
		≥ 55	Insulated ceramic balls	
≥ 460 V	≥ 1500	≤ 55	Standard	Standard
		> 55	Insulated ceramic balls	Standard + earth ring

Bearings with grease nipples

The bearings are lubricated in the factory
The end shields are fitted with bearings lubricated by Técalémit grease nipples.

The frequency of lubrication and quantity and quality of grease are indicated on the nameplates. Refer to these to ensure correct lubrication of the bearings.

Even in the event of prolonged storage or downtime, the interval between two greasing operations must never exceed 2 years.

Permissible loads

Permissible loads: Motors in the 1500 to 2400 series are designed to operate with direct or indirect coupling; permissible loads on request. Motors in the 3000 to 5500 series are designed to operate with direct coupling. For other cases, please consult Leroy-Somer.

CAUTION:
Transmission via belt pulleys is only authorized up to series 2400.

Precautions

For the 4500 and 5500 series, a running-in period is necessary. Please refer to installation and maintenance manual reference 4155.

Greasing (standard)

Frame size	Speed (rpm)	Lubrication type	Grease
< 225	All	Permanently greased bearings	ENS, WT or BQ 72-72
≥ 225	N ≤ 3600	Bearings with grease nipples	Polyrex EM 103
	N > 3600	Bearings with grease nipples	BQ 72-72

Lubrication intervals

Series	Type	Bearing types		Relubrication intervals in hours																					
				1500 rpm			1800 rpm			2400 rpm			3000 rpm			3600 rpm			4500 rpm			5500 rpm			
		N.D.E.	D.E.	25°C	40°C	55°C	25°C	40°C	55°C	25°C	40°C	55°C	25°C	40°C	55°C	25°C	40°C	55°C	25°C	40°C	55°C	25°C	40°C	55°C	
LSRPM	200 L	6214 C3	6312 C3	26200	13100	6550	22200	11100	5550	16000	8000	4000	14600	7300	3650	10400	5200	2600	-	-	-	-	-	-	
	200 L1			-	-	-	-	-	-	-	-	16000	8000	4000	11400	5700	2850	8200	4100	2050	8000	4000	2000	-	-
	200 L2	-	-	-	-	-	-	-	-	-	-	-	-	-	-	-	-	-	-	-	-	-	-	-	
	200 L1	6212 C3	6212 C3	-	-	-	-	-	-	-	-	-	-	-	-	-	-	-	-	-	-	6800	3400	1700	
	200 L2			-	-	-	-	-	-	-	-	-	-	-	-	-	-	-	-	-	-	-	5400	2700	1350
	200 LU	6312 C3	6312 C3	26800	13400	6700	-	-	-	-	-	-	-	-	-	-	-	-	-	-	-	-	-	-	-
	200 LU2			-	-	-	-	-	-	-	-	-	-	-	-	-	8600	4300	2150	8600	4300	2150	-	-	-
	225 ST1	6214 C3	6313 C3	25200	12600	6300	21200	10600	5300	-	-	-	-	-	-	-	-	-	-	-	-	-	-	-	-
	225 ST2			-	-	-	-	-	-	-	-	-	-	10600	5300	2650	-	-	-	-	-	-	-	-	-
	225 MR1	6312 C3	6313 C3	25200	12600	6300	21200	10600	5300	15000	7500	3750	-	-	-	-	-	-	-	-	-	-	-	-	-
	225 SR2			-	-	-	-	-	-	-	-	-	-	-	-	-	-	-	7000	3500	1750	-	-	-	-
	225 SG	6216 C3	6314 C3	-	-	-	-	-	-	-	-	-	-	-	-	8000	4000	2000	-	-	-	-	-	-	
	250 SE	-	-	-	-	-	-	-	-	13600	6800	3400	9200	4600	2300	-	-	-	-	-	-	-	-	-	-
	250 SE1	6216 C3	6314 C3	-	-	-	-	-	-	-	-	-	-	-	-	6400	3200	1600	5800	2900	1450	-	-	-	
	250 ME			23600	11800	5900	19600	9800	4900	13600	6800	3400	-	-	-	-	-	-	-	-	-	-	-	-	-
	250 ME1	-	-	-	-	-	-	-	-	-	-	-	9200	4600	2300	-	-	-	-	-	-	-	-	-	
	250 MY	6214 C3	6313 C3	25200	12600	6300	-	-	-	-	-	-	-	-	-	-	-	-	-	-	-	-	-	-	
	280 SC	6216 C3	6316 C3	20800	10400	5200	16800	8400	4200	-	-	-	-	-	-	-	-	-	-	-	-	-	-	-	
	280 SCM			20800	10400	5200	-	-	-	-	-	-	-	-	-	-	-	-	-	-	-	-	-	-	-
	280 SD	6218 C3	6316 C3	20800	10400	5200	16800	8400	4200	-	-	-	-	-	-	-	-	-	-	-	-	-	-	-	
280 SD1	-			-	-	-	-	-	11000	5500	2750	7200	3600	1800	4600	2300	1150	-	-	-	-	-	-		
280 MK1	6317 C3	6317 C3	19600	9800	4900	15600	7800	3900	10000	5000	2500	6400	3200	1600	4000	2000	1000	-	-	-	-	-	-		
315 SN	6218 C3	6317 C3	19600	9800	4900	-	-	-	-	-	-	-	-	-	-	-	-	-	-	-	-	-	-		
315 SP1	6317 C3	6317 C3	19600	9800	4900	15600	7800	3900	10000	5000	2500	6400	3200	1600	-	-	-	-	-	-	-	-	-		
315 MP1	-	-	15800	7900	3950	-	-	-	-	-	-	-	-	-	-	-	-	-	-	-	-	-	-		
315 SR1	6317 C3	6320 C3	-	-	-	-	-	-	7000	3500	1750	-	-	-	-	-	-	-	-	-	-	-	-		
315 MR1			15800	7900	3950	12000	6000	3000	7000	3500	1750	-	-	-	-	-	-	-	-	-	-	-	-		
PLSRPM	315 LD1	6316 C3	6224 C3	14600	7300	3650	11000	5500	2750	-	-	-	-	-	-	-	-	-	-	-	-	-	-		
	315 LD1	6316 C3	6219 C3	-	-	-	-	-	-	-	-	6400	3200	1600	4000	2000	1000	-	-	-	-	-	-		

Terminal box

Placed as standard on the top of the motor near the drive end, the terminal box has IP55 protection.

The standard position of the cable gland baseplate is on the right, seen from the drive end, position A1.

▼ Terminal box positions in relation to the drive end

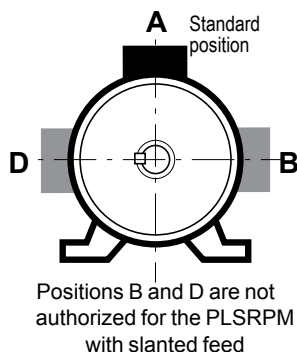

▼ Positions of the cable gland in relation to the motor drive shaft

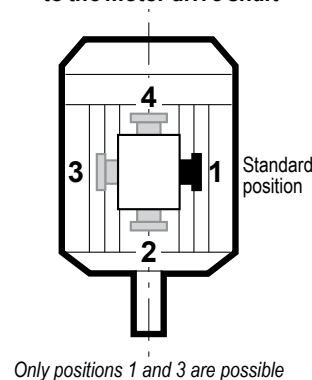

Dimensions of motor connection terminals

Motors with frame size ≤ 160

Frame size	Speed (rpm)	Terminals
90	all	M5
100 and 132	all	M6
160	N ≤ 2400	M6
	N > 2400	M8

Motors with frame size ≥ 200

Motor current (A)	Terminals
≤ 63	M6
63 < I ≤ 125	M10
200 < I ≤ 320	M12
I > 320	M16

Position of the cable glands	1	2*	3	4
LSRPM	●	●	●	●
PLSRPM	●	-	●	●

* not recommended (impossible on motor with smooth hole flange)

- standard
- possible by turning the terminal box
- please call (not authorized in certain cases)

Terminal box drilling for cable glands

Motor type	Power + auxiliaries		
	Number of drill holes	Drill hole diameter	
LSRPM 160 LR/MP	3	ISO M50x1.5 + 1xM16 for speed ≤ 2400 rpm: ISO M40x1.5 + 1xM16	
LSRPM 200 L/LU		2xM40 + 1xM16	
LSRPM 200 L1		2xM50 + 1xM16	
LSRPM 200 L2/LU2		2xM63 + 1xM16	
LSRPM 225 ST1/MR1, LSRPM 250 MY		2xM50 + 1xM16	
LSRPM 225 SG/ST2/SR2		2xM63 + 1xM16	
LSRPM 250 SE/ME		2xM63 + 1xM16	
LSRPM 250 SE1/ME1		Removable undrilled mounting plate	
LSRPM 280 SD/MD/SC/SCM		2xM63 + 1xM16	
LSRPM 280 SD1/MK1		0	Removable undrilled mounting plate
LSRPM 315 SP1/MR1/SN/MP1/SR1			
PLSRPM 315 LD1			

The standard delivery of the motors is without cable gland.

A cable gland option with anchoring on armoured cable is available for pre-drilled terminal boxes.

Working dimensions for drilling the removable plate (supplied not drilled)

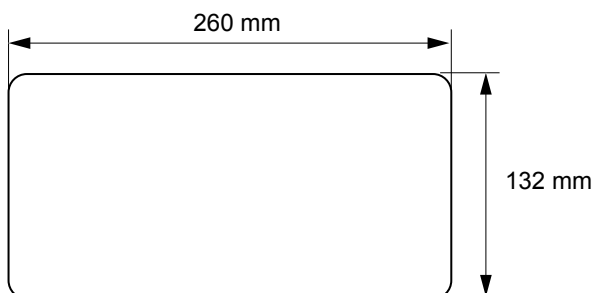

Specifics of terminal boxes with feed for PLSRPM motors

PLSRPM motors feature a terminal box allowing connection on stepped copper strips (3 levels) in standard.

From 400 kW (400V power supply), they feature an inclined extended feed in standard to facilitate wiring. A straight or inclined extension feed is also proposed as an option for all PLSRPMs.

Speed	Power PLSRPM 315 LD1 (kW)	Terminal box with inclined feed	Terminal box with straight feed
1500	315	●	●
1500	355	●	●
1800	355	●	●
1800	400	●	●
3000	355	●	●
3000	400	●	●
3000	450	●	●
3000	500	●	●
3600	315	●	●
3600	355	●	●
3600	400	●	●
3600	450	●	●
3600	500	●	●

● standard
● proposed as an option

Terminal box with inclined extension feed PLSRPM

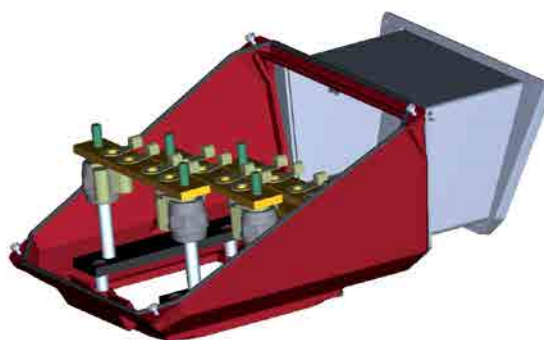
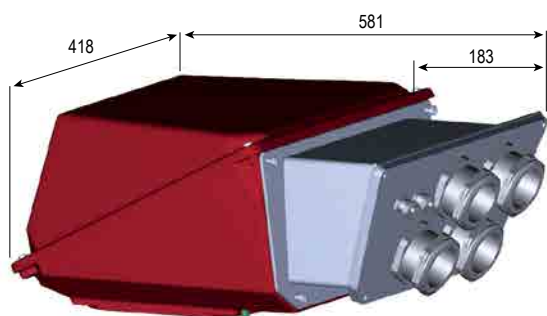

The motors are delivered without cable gland in standard.

Terminal box with straight extension feed PLSRPM

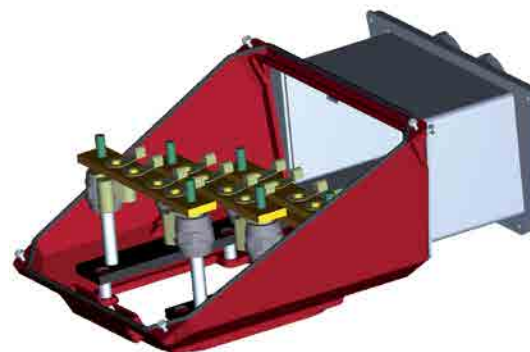
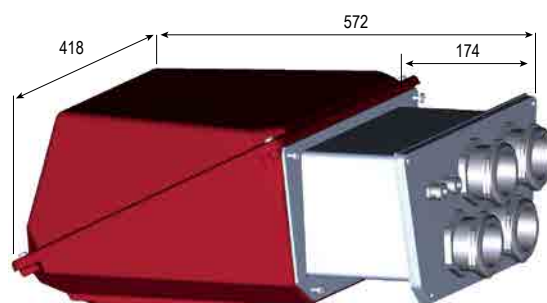

The motors are delivered without cable gland in standard.

To obtain the complete dimensions of the motors, and more particularly those of terminal boxes without feed, refer to the "Motor dimensions" section.

Motor construction

Terminal box and connection

Principle for connecting the terminal block

LSRPM motors

Axis height < 160

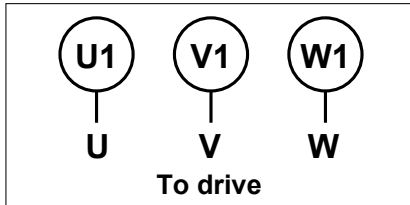

Axis height > 160

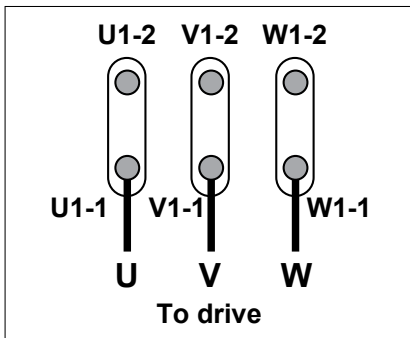

Do not change the position of the strips, they are not coupling strips.
To reverse the rotation, refer to the manual of the corresponding drive.

PLSRPM motors

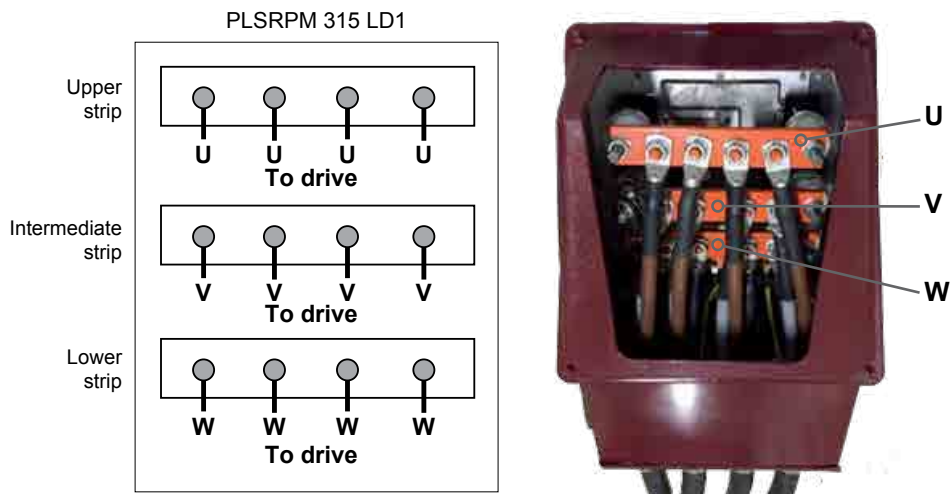

For more detailed information on the connection, refer to the installation and maintenance manual of the LSRPM-PLSRPM motors, reference 4155.

Maximum vibration magnitude limits (rms values) in terms of displacement, speed and acceleration for a frame size H (IEC 60034-14)

The motors in this catalogue are in vibration class:
 - level A as standard
 - level B optionally for $n \leq 3600$ rpm
 and are balanced with a half-key (H)

Vibration level	Frame size H (mm)					
	160 ≤ H ≤ 280			H > 280		
	Displacement mm	Speed mm/s	Acceleration m/s ²	Displacement μm	Speed mm/s	Acceleration m/s ²
A	35	2.2	3.5	45	2.8	4.4
B	18	1.1	1.7	29	1.8	2.8

Dyneo® motors are balanced with a half-key in accordance with standard ISO 8821. Any coupling element (pulley, coupling sleeve, slip-ring, etc.) must therefore be balanced accordingly.

Quality commitment

Leroy-Somer's quality management system is based on:

- Control of procedures right from the initial sales offering until delivery to the customer, including design, manufacturing start-up and production

- A total quality policy based on making continuous progress in improving operational procedures, involving all departments in the company in order to give customer satisfaction as regards delivery times, conformity and cost

- Indicators used to monitor procedural performance

- Corrective actions and advancements with tools such as FMECA, QFD, MAVP, MSP/MSQ and Hoshin type improvement workshops on flows, process re-engineering, plus Lean Manufacturing and Lean Office

- Annual surveys, opinion polls and regular visits to customers in order to ascertain and detect their expectations.

Personnel are trained and take part in analyses and actions for continuous improvement of our procedures.

Leroy-Somer has entrusted the certification of its expertise to various international organisations.

Certification is granted by independent professional auditors, and recognises the high standards of the **company's quality assurance procedures**. All activities resulting in the final version of the machine have therefore received official certification **ISO 9001: 2008 from the DNV**. Similarly, our environmental approach has enabled us to obtain certification ISO 14001: 2004. Products for particular applications or those designed to operate in specific environments are also approved or certified by the following organisations: LCIE, DNV, INERIS, EFECTIS, UL, BSRIA, TUV, GOST, that check their technical performance against the various standards or recommendations.



ISO 9001 : 2008



**Motors comply with the standards
quoted in this catalogue**

List of standards quoted in this document

Reference		International standards
IEC 60034-1	EN 60034-1	Rotating electrical machines: rating and performance.
IEC 60034-2		Rotating electrical machines: methods for determining losses and efficiency from tests (additional losses added as a fixed percentage)
IEC 60034-2-1		Rotating electrical machines: methods for determining losses and efficiency from tests (measured additional losses)
IEC 60034-5	EN 60034-5	Rotating electrical machines: degrees of protection provided by the integral design of rotating electrical machines
IEC 60034-6	EN 60034-6	Rotating electrical machines (except traction): methods of cooling.
IEC 60034-7	EN 60034-7	Rotating electrical machines (except traction): classification of types of construction, mounting arrangements and terminal box position.
IEC 60034-8		Rotating electrical machines: terminal markings and direction of rotation.
IEC 60034-9	EN 60034-9	Rotating electrical machines: noise limits.
IEC 60034-12	EN 60034-12	Starting performance of single-speed three-phase cage induction motors for voltages up to and including 660 V.
IEC 60034-14	EN 60034-14	Rotating electrical machines: mechanical vibration of certain machines with shaft heights 56 mm and higher. Measurement, evaluation and limits of vibrational intensity
IEC 60034-17		Cage induction motors when fed from converters - Application guide
IEC 60034-30-1		Rotating electrical machines: efficiency classes of single-speed, three-phase cage-induction motors (IE-code).
IEC 60038		IEC standard voltages.
IEC 60072-1		Dimensions and output series for rotating electrical machines: designation of casings between 56 and 400 and flanges between 55 and 1080.
IEC 60085		Electrical insulation - thermal evaluation and designation.
IEC 60721-2-1		Classification of environmental conditions. Temperature and humidity
IEC 60892		Effects of unbalanced voltages on the performance of 3-phase cage induction motors
IEC 61000-2-10/11 and 2-2		Electromagnetic compatibility (EMC): environment.
IEC guide 106		Guidelines on the specification of environmental conditions for the determination of operating characteristics of equipment.
ISO 281		Bearings - Dynamic load ratings and nominal bearing life
ISO 1680	EN 21680	Acoustics - Test code for the measurement of airborne noise emitted by rotating electrical machines: a method for establishing an expert opinion for free field conditions over a reflective surface.
ISO 8821		Mechanical vibration - Balancing. Shaft and fitment key conventions.
	EN 50102	Degree of protection provided by electrical enclosures against extreme mechanical impacts.
ISO 12944-2		Corrosion protection.

Approvals

Certain countries recommend or insist on approval from national organizations. Approved products must carry the recognized mark on their nameplates.

Country	Acronym	Organization
USA	UL	Underwriters Laboratories
CANADA	CSA	Canadian Standards Association
etc.		

Approvals for Leroy-Somer motors (versions derived from standard construction):

Country	Acronym	Certification No.	Application
CANADA	CSA	LR 57 008	Standard adapted range (see section "Supply voltage")
USA	UL or FJ	E 68554 SA 6704 E 206450	Impregnation systems Stator/rotor assemblies for sealed units Complete motors up to 160 size
USA + Canada		E 68554	Impregnation systems
SAUDI ARABIA	SASO		Standard range
FRANCE	LCIE INERIS	Various nos.	Sealing, shocks, safety

For approved special products, see the relevant documents.

International and national standard equivalents

International reference standards		National standards				
IEC	Title (summary)	FRANCE	GERMANY	UK	ITALY	SWITZERLAND
60034-1	Ratings and operating characteristics	NFEN 60034-1 NFC 51-120 NFC 51-200	DIN/VDE 0530	BS 4999	CEI 2.3.VI.	SEV ASE 3009
60034-5	Classification of degrees of protection	NFEN 60034-5	DIN/EN 60034-5	BS EN 60034-5	UNEL B 1781	
60034-6	Cooling methods	NFEN 60034-6	DIN/EN 60034-6	BS EN 60034-6		
60034-7	Mounting arrangements and assembly layouts	NFEN 60034-7	DIN/EN 60034-7	BS EN 60034-7		
60034-8	Terminal markings and direction of rotation	NFC 51 118	DIN/VDE 0530 Teil 8	BS 4999-108		
60034-9	Noise limits	NFEN 60034-9	DIN/EN 60034-9	BS EN 60034-9		
60034-12	Starting characteristics for single-speed motors for supply voltages ≤ 660 V	NFEN 60034-12	DIN/EN 60034-12	BS EN 60034-12		SEV ASE 3009-12
60034-14	Mechanical vibrations of machines with frame size ≥ 56 mm	NFEN 60034-14	DIN/EN 60034-14	BS EN 60034-14		
60072-1	Dimensions and output powers for machines between 56 and 400 frame size and flanges between 55 and 1080.	NFC 51 104 NFC 51 105	DIN 748 (-) DIN 42672 DIN 42673 DIN 42631 DIN 42676 DIN 42677	BS 4999		
60085	Evaluation and thermal classification of electrical insulation	NFC 26206	DIN/EN 60085	BS 2757		SEV ASE 3584

NB: DIN 748 tolerances do not conform to IEC 60072-1.

Nameplates

Identification

As soon as you receive the motor, check that the nameplate on the machine conforms to your order.

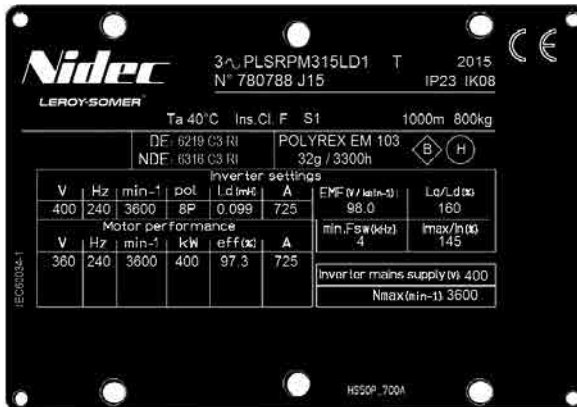
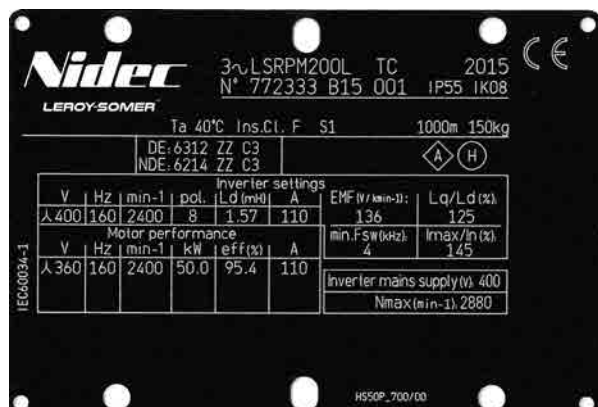

Definition of symbols used on nameplates:



Legal mark of conformity of product to the requirements of European Directives

3 ~ : Three-phase A.C. motor

LSRPM : Series

200 : Frame size

L : Housing designation and manufacturer code

TC : Impregnation index

Motor

772333 : Motor batch number

B : Month of production

15 : Year of production

001 : Serial number

IP55 IK08 : Ingress protection

Ins. cl. F : Insulation class F

Ta 40°C : Ambient operating temperature

S : Duty

% : Operating factor

1000 m : Maximum altitude without derating

kg : Weight

RI : Insulated bearing

DE : Drive end bearing

NDE : Non drive end bearings

12 g : Amount of grease at each regreasing

2200 hrs : Regreasing interval (in hours) for the ambient temperature (Ta)

QUIET BQ 72-72: Type of grease

A : Vibration level

H : Balancing mode

Inverter settings : Parameters to be entered in the drive

EMF (V/kmin⁻¹) : Electromotive force

Lq/Ld % : Cogging ratio

min.Fsw (kHz) : Minimum switching frequency

Imax/In % : Maximum current ratio/Rated current

V : Voltage

Hz : Supply frequency

min⁻¹ : Revolutions per minute (rpm)

pol. : Number of poles

Ld (mH) : Transient inductance

A : Rated current

Motor performance: Motor characteristics

V : Voltage

Hz : Supply frequency

min⁻¹ : Revolutions per minute (rpm)

kW : Rated power

Eff % : Efficiency

A : Rated current

Inverter mains supply (V): Drive AC supply voltage

Nmax (min⁻¹) : Maximum speed

Dyneo® Motors & Drives

Powerdrive FX & MD2 variable speed drives/LSRPM-PLSRPM permanent magnet synchronous motors

General information

Configurator



The Leroy-Somer configurator can be used to choose the most suitable motors and drives and provides the technical specifications and corresponding drawings.

Register online at
www.leroy-somer.com/fr/solutions_et_services/systemes_entrainement/configurateur

- Help with product selection
- Print-outs of technical specifications
- Print-outs of 2D and 3D CAD files
- The equivalent of 300 catalogs in 10 languages

Notes

LEROY-SOMER[™]

www.nidecautomation.com

Connect with us at:

twitter.com/Leroy_Somer

facebook.com/leroy-somer.nidec

youtube.com/user/LeroySomerOfficiel

theautomationengineer.com (blog)



Nidec
All for dreams

Moteurs Leroy-Somer SAS. Headquarters: Bd Marcellin Leroy, CS 10015, 16915 Angoulême Cedex 9, France. Share Capital: 65 800 512 €, RCS Angoulême 338 567 258.